



**BUILDPRO**<sup>®</sup>



Welding Tables

# 2021 Catalog

Welding Tables · Platforms · Fixturing Elements · Mobile Working Stations

**StrongHandTools**<sup>®</sup>

StrongHandTools.com 800.989.5244



# BUILDPRO SYSTEM

BuildPro offers a complete line of heavy-duty and ultra-duty tables for work holding in metal fabrication and woodworking. Our tried and tested system is the fastest method of locating and clamping your workpieces. The system consists of a working surface machined with equally spaced boreholes, allowing you to slip-fit clamps, stops, spacers, and other work holding tools into place.



## ALPHA TABLES

The new heavy-duty table line from BuildPro; it features 5 sides fitted with 5/8" diameter boreholes for more versatility and expandability than before. Maintaining industry-leading requirements for flatness, squareness, and dimensional accuracy. Also available in ultra-duty 28 mm configurations.



## MAX TABLES

Our single-sided heavy-duty tables feature boreholes on the top surface and feature patented self-locating and reversible table top plates. Available in standard and nitrided tabletop finishes.



## MAX SLOTTED TABLES

Our slotted, single-sided heavy-duty tables feature open slots between the top plates. Providing extra versatility, allowing you to slide clamping tools or pliers using T-Slot adapters or Sliding Channel on the open slot edges as clamping surfaces. Available in standard and nitrided tabletop finishes.



## MOBILE WORKING STATIONS

Get the best of both worlds; the functionality and quality of BuildPro tables with the mobility of a cart. The Rhino Cart and Manipulator feature a replaceable heavy-duty tabletop that accepts all 5/8" diameter TM fixturing components - giving you the ultimate, compact mobile working stations.

# Contents

<p><b>TABLES &amp; ACCESSORIES</b> 04 - 25</p>							
<p><b>MOBILE WORKING STATIONS</b> 26 - 31</p>							
<p><b>PLATFORMS</b> 32 - 35</p>							
<p><b>CLAMPS &amp; PLIERS</b> 36 - 43</p>							
<p><b>FASTENERS</b> 44 - 46</p>							
<p><b>STOPS</b> 47 - 48</p>							
<p><b>CLAMPING SQUARES</b> 49 - 52</p>							
<p><b>RESTS</b> 53 - 57</p>							
<p><b>SPECIAL TOOLS</b> 58 - 65</p>							
<p><b>FIXTURING KITS</b> 66 - 71</p>							

\* All product, product specifications and data are subject to change without notice to improve reliability, function, design or otherwise. Please check online for updated information and details.

⚠ **WARNING:** Cancer and Reproductive Harm - [www.P65Warnings.ca.gov](http://www.P65Warnings.ca.gov)



# THE NEW FIVE-SIDED ALPHA WELDING TABLE

Introducing the Alpha series, the toughest, flattest, hardest working welding tables from BuildPro by Strong Hand Tools.

The Alpha family consists of our 5 sided table systems, combined with our patent-exclusive, reversible, and replaceable top and side plates.

Precision ground steel plates, with CNC machined  $\text{\O}5/8$ " holes in a 2" grid pattern for locating, positioning and mounting BuildPro clamps and accessories.

Plates can be reconfigured to expand the width of the table for larger projects.

Heavy Duty Leveling Feet ensure proper leveling of the table on uneven surfaces.

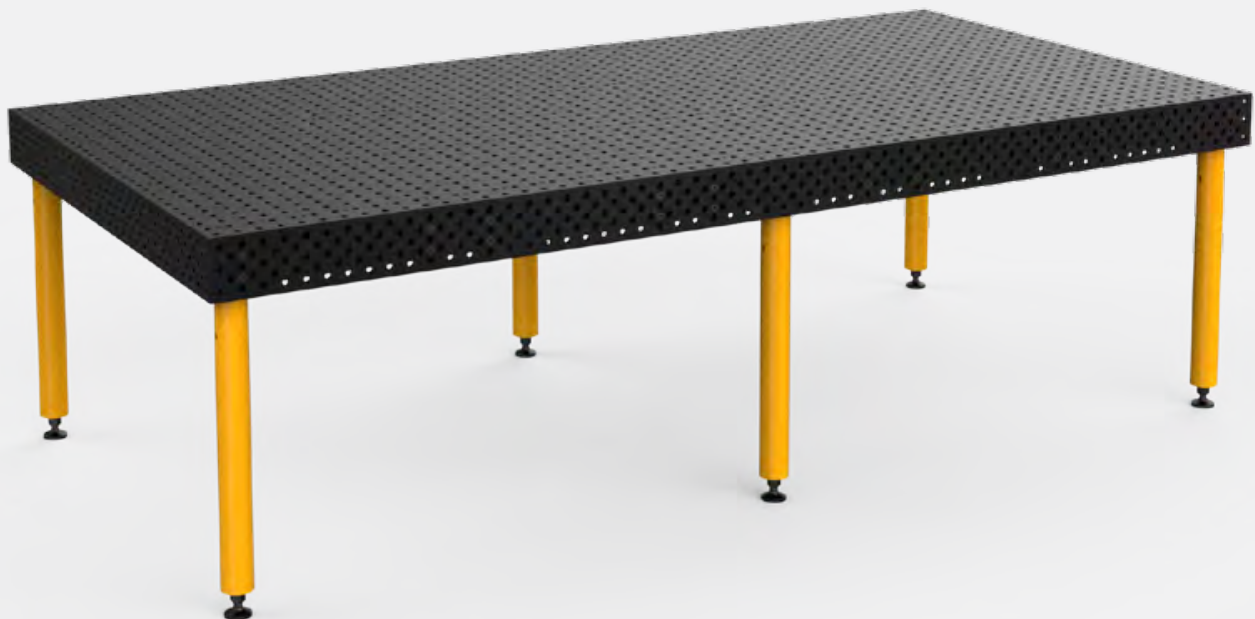

**Increase quality, consistency, and productivity while reducing scrap and setup times for repeating jobs.**



## ALPHA TABLE OVERVIEW



### REVERSIBLE Self-Locating Top & Side Plates

All BuildPro welding tables feature precision machined self-locating steel plates and reversible top plates; this enables each table plate to be removed and flipped 180 degrees to expose a new working surface if the top side has been damaged or worn down.

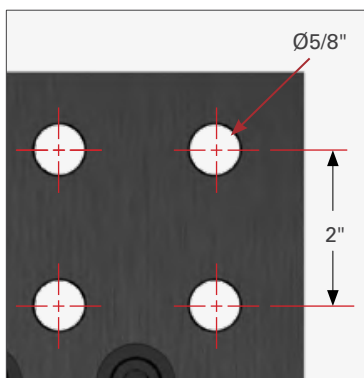

### Alpha Table Accuracy

**Table flatness:**  $\pm 0.005$ " per 24" x 24"

**Hole spacing:** 2.000"  $\pm 0.001$

**Hole diameter:** 0.625"  $\pm .002$   
 $\pm .000$

**Plate thickness:** 0.47"  $\pm 0.004$

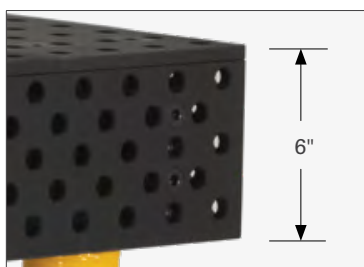

### Alpha Tabletop Side Height

The new five-sided tables feature a 5-1/2" side plate combined with the top plate to create a 6" height.

Alpha table side plates feature an extended 5 borehole pattern for added precision and adjust-ability.

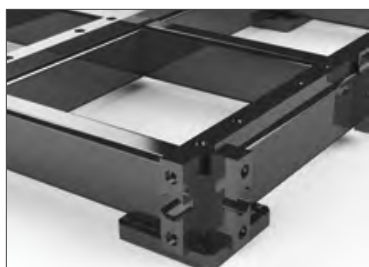

### Plate Mounting Detail for Side Plates

Side Plates also use self locating bushing system.



### Nitrided (Heat-Treated) Tabletop

All top and side plates of alpha table are constructed from heat-treated steel, hardened to 58-62 HRC(top) / 50-55 HRC(side), and finished with a nitrite coating with a case depth of .0004-.0008".

## TABLE SURFACE DIMENSION: 120" X 60" (ACTUAL)

*\*All load capacities below are calculated based on static load.*



Part No.	TA5-12060Q-A1	TA5-12060Q-A2
Finish	Nitrided	Nitrided
Comes with Leg	6x TML3130	6x TML2530
Table Surface Height (in)	36.3	30.3
Capacity / Leg (lb)	1,500	1,500
Gross Weight (lb)	1,902	1,890



Part No.	TA5-12060Q-B1
Finish	Nitrided
Comes with Leg	6x TMLR30
Table Surface Height (in)	28.3 ~ 38.3
Capacity / Leg (lb)	1,500
Gross Weight (lb)	1,923



Part No.	TA5-12060Q-C1
Finish	Nitrided
Comes with Leg	6x TMLC30
Table Surface Height (in)	33 ~ 43
Capacity / Leg (lb)	650
Gross Weight (lb)	1,958

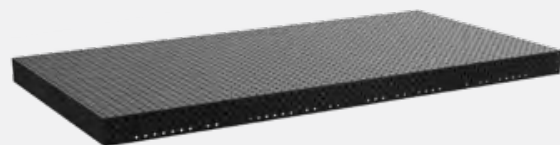

### ALPHA, 10' X 5' TABLETOP

Part No.	Finish	Dimension (in)	Gross Weight (lb)
TA5-12060Q-N	Nitrided	120 x 60	1,821

### INDIVIDUAL PLATES

Ref.	Part No.	Dimension (in)	Weight (lb)	Thickness (in)
A	TY5-A600080Q-01	60 x 8	58.6	0.47
B	TY5-A590055Q-04	59 x 5.5	36.7	
C	TY5-A485055Q-03	48.5 x 5.5	30.1	
D	TY5-A470055Q-04	47 x 5.5	29.1	
E	TY5-A245055Q-06	24.5 x 5.5	15.2	

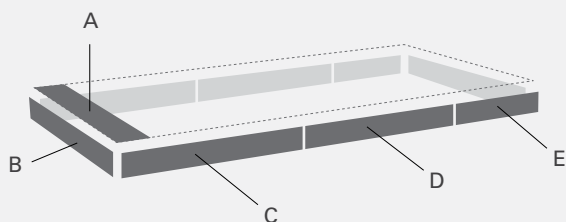

# 8' X 4' TABLES

## TABLE SURFACE DIMENSION: 96" X 48" (ACTUAL)

\*All load capacities below are calculated based on static load.



<b>Part No.</b>	TA5-9648Q-A1	TA5-9648Q-A2
<b>Finish</b>	Nitrided	Nitrided
<b>Comes with Leg</b>	6x TML3130	6x TML2530
<b>Table Surface Height (in)</b>	36.3	30.3
<b>Capacity / Leg (lb)</b>	1,500	1,500
<b>Gross Weight (lb)</b>	1,409	1,397



<b>Part No.</b>	TA5-9648Q-B1
<b>Finish</b>	Nitrided
<b>Comes with Leg</b>	6x TMLR30
<b>Table Surface Height (in)</b>	28.3 ~ 38.3
<b>Capacity / Leg (lb)</b>	1,500
<b>Gross Weight (lb)</b>	1,430



<b>Part No.</b>	TA5-9648Q-C1
<b>Finish</b>	Nitrided
<b>Comes with Leg</b>	6x TMLC30
<b>Table Surface Height (in)</b>	33 ~ 43
<b>Capacity / Leg (lb)</b>	650
<b>Gross Weight (lb)</b>	1,465



### ALPHA, 8' X 4' TABLETOP

Part No.	Finish	Dimension (in)	Gross Weight (lb)
TA5-9648Q-N	Nitrided	96 x 48	1,328

### INDIVIDUAL PLATES

Ref.	Part No.	Dimension (in)	Weight (lb)	Thickness (in)
A	TY5-A480080Q-01	48 x 8	46.8	0.47
B	TY5-A485055Q-03	48.5 x 5.5	30.1	
C	TY5-A475055Q-06	47.5 x 5.5	29.5	
D	TY5-A470055Q-04	47 x 5.5	29.1	

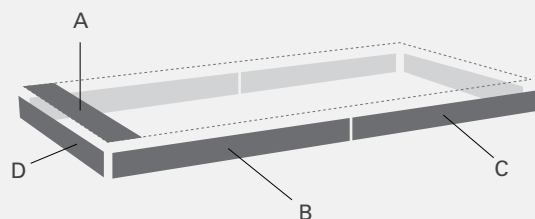



## TABLE SURFACE DIMENSION: 72" X 48" (ACTUAL)

\*All load capacities below are calculated based on static load.



Part No.	TA5-7248Q-A1	TA5-7248Q-A2
Finish	Nitrided	Nitrided
Comes with Leg	6x TML3130	6x TML2530
Table Surface Height (in)	36.3	30.3
Capacity / Leg (lb)	1,500	1,500
Gross Weight (lb)	1,077	1,065



Part No.	TA5-7248Q-B1
Finish	Nitrided
Comes with Leg	6x TMLR30
Table Surface Height (in)	28.3 ~ 38.3
Capacity / Leg (lb)	1,500
Gross Weight (lb)	1,098



Part No.	TA5-7248Q-C1
Finish	Nitrided
Comes with Leg	6x TMLC30
Table Surface Height (in)	33 ~ 43
Capacity / Leg (lb)	650
Gross Weight (lb)	1,133

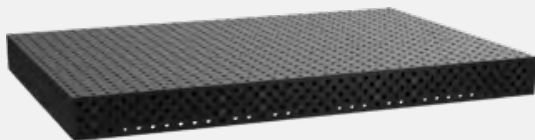

### ALPHA, 6' X 4' TABLETOP

Part No.	Finish	Dimension (in)	Gross Weight (lb)
TA5-7248Q-N	Nitrided	72 x 48	995

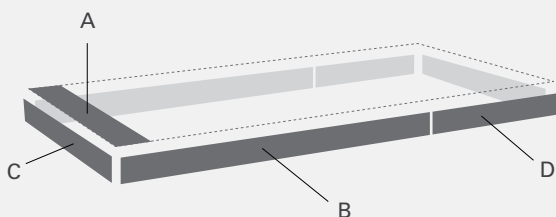

### INDIVIDUAL PLATES

Ref.	Part No.	Dimension (in)	Weight (lb)	Thickness (in)
A	TY5-A480080Q-01	48 x 8	46.8	0.47
B	TY5-A485055Q-03	48.5 x 5.5	30.1	
C	TY5-A470055Q-04	47 x 5.5	29.1	
D	TY5-A235055Q-06	23.5 x 5.5	14.6	

# 6' X 3' TABLES

## TABLE SURFACE DIMENSION: 72" X 36" (ACTUAL)

*\*All load capacities below are calculated based on static load.*



<b>Part No.</b>	TA5-7236Q-A1	TA5-7236Q-A2
<b>Finish</b>	Nitrided	Nitrided
<b>Comes with Leg</b>	6x TML3130	6x TML2530
<b>Table Surface Height (in)</b>	36.3	30.3
<b>Capacity / Leg (lb)</b>	1,500	1,500
<b>Gross Weight (lb)</b>	934	921



<b>Part No.</b>	TA5-7236Q-B1
<b>Finish</b>	Nitrided
<b>Comes with Leg</b>	6x TMLR30
<b>Table Surface Height (in)</b>	28.3 ~ 38.3
<b>Capacity / Leg (lb)</b>	1,500
<b>Gross Weight (lb)</b>	954



<b>Part No.</b>	TA5-7236Q-C1
<b>Finish</b>	Nitrided
<b>Comes with Leg</b>	6x TMLC30
<b>Table Surface Height (in)</b>	33 ~ 43
<b>Capacity / Leg (lb)</b>	650
<b>Gross Weight (lb)</b>	989



### ALPHA, 6' X 3' TABLETOP

Part No.	Finish	Dimension (in)	Gross Weight (lb)
TA5-7236Q-N	Nitrided	72 x 36	852

### INDIVIDUAL PLATES

Ref.	Part No.	Dimension (in)	Weight (lb)	Thickness (in)
A	TY5-A360080Q-01	36 x 8	35.0	0.47
B	TY5-A485055Q-03	48.5 x 5.5	30.1	
C	TY5-A350055Q-04	35 x 5.5	21.6	
D	TY5-A235055Q-06	23.5 x 5.5	14.6	

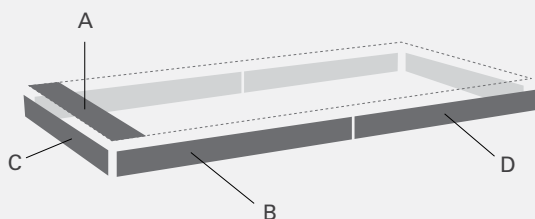

## TABLE SURFACE DIMENSION: 48" X 48" (ACTUAL)

\*All load capacities below are calculated based on static load.



Part No.	TA5-4848Q-A1	TA5-4848Q-A2
Finish	Nitrided	Nitrided
Comes with Leg	4xTML3130	4xTML2530
Table Surface Height (in)	36.3	30.3
Capacity / Leg (lb)	1,500	1,500
Gross Weight (lb)	740	732

Part No.	TA5-4848Q-B1
Finish	Nitrided
Comes with Leg	4xTMLR30
Table Surface Height (in)	28.3 ~ 38.3
Capacity / Leg (lb)	1,500
Gross Weight (lb)	754

Part No.	TA5-4848Q-C1
Finish	Nitrided
Comes with Leg	4xTMLC30
Table Surface Height (in)	33 ~ 43
Capacity / Leg (lb)	650
Gross Weight (lb)	778



### ALPHA, 4' X 4' TABLETOP

Part No.	Finish	Dimension (in)	Gross Weight (lb)
TA5-4848Q-N	Nitrided	48 x 48	686

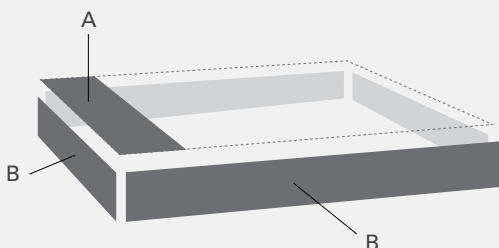

### INDIVIDUAL PLATES

Ref.	Part No.	Dimension (in)	Weight (lb)	Thickness (in)
A	TY5-A480080Q-01	48 x 8	46.8	0.47
B	TY5-A475055Q-06	47.5 x 5.5	29.5	





Alpha tables available in both metric and inch spacing and 28 mm, and 5/8" diameter boreholes, respectively. All top plates are constructed from heat-treated steel, hardened to 58-62 HRC, and finished with a nitrite coating with a case depth of .0004-.0008".

### ALPHA 28 TABLES

### ALPHA 5/8 TABLES

Table Hole Dia.	28 mm (1.1")	5/8"
Hole Spacing	100 mm (3.9")	2.000"
Table Flatness	$\pm 0.125$ mm per 600 x 600 mm ( $\pm 0.005$ " per 24" x 24")	$\pm 0.005$ " per 24" x 24"
Plate Thickness	$25 \pm 0.06$ mm (1" $\pm 0.002$ )	0.47" $\pm 0.004$
Tabletop Side Height	200 mm (7.9")	6"

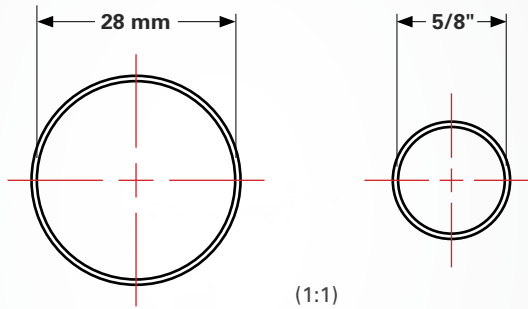

Check our website: [buildprotables.com](http://buildprotables.com) for more details about Alpha 28 table system.

**MAX TABLE OVERVIEW**



**Reversible, Self-Locating Plates**

Patented Bushing design allows you to remove, re-position, re-align, and reverse the table plates!

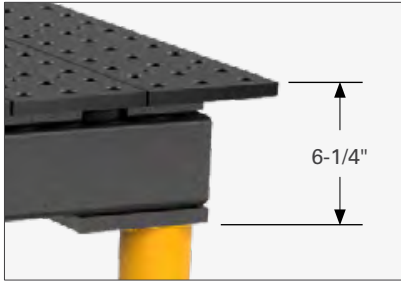

**Tabletop Side Height**

6-1/4" for both MAX and MAX Slotted tables

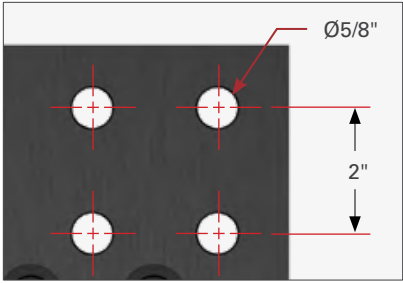

**MAX Table Accuracy**

**Table flatness:**  $\pm 0.005$ " per 24" x 24"  
**Hole spacing:**  $2.000 \pm 0.001$   
**Hole diameter:**  $0.625 \begin{smallmatrix} +.002 \\ -.000 \end{smallmatrix}$   
**Plate thickness:**  $0.630 \pm 0.004$



**New MAX table sizes available: 6' x 4' and 5' x 3'**

*See pg. 14 - 15*

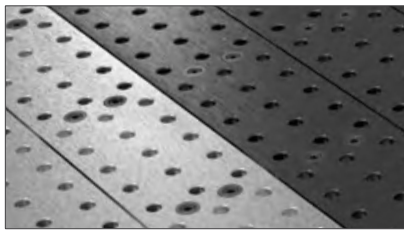

**Standard (plain) / Nitrided Finish**

Choose from standard finish (medium carbon steel) or Nitrided (heat-treating) finish.



**MAX Tables**

Maximum Table Surface, Maximum Capacity. Utilize the additional holes (33% more than slotted tables) for clamping at multiple points.

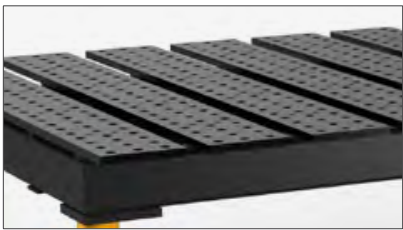

**MAX Slotted Tables**

All slotted tables have 1.7" slots between plates.

# 8' X 4' TABLES

U.S. PAT. 8065967

**MAX**

## TABLE SURFACE DIMENSION: 96" X 48" (ACTUAL)

\*All load capacities below are calculated based on static load.



Part No.	TMA59648F	TMB59648F	TMQA59648F	TMQB59648F
Finish	Standard	Standard	Nitrided	Nitrided
Comes with Leg	6x TML3130	6x TML2530	6x TML3130	6x TML2530
Table Surface Height (in)	36.5	30.5	36.5	30.5
Capacity / Leg (lb)	1,500	1,500	1,500	1,500
Gross Weight (lb)	1,370	1,358	1,370	1,358



Part No.	TMR59648F	TMQR59648F
Finish	Standard	Nitrided
Comes with Leg	6x TMLR30	6x TMLR30
Table Surface Height (in)	28.5 ~ 38.5	28.5 ~ 38.5
Capacity / Leg (lb)	1,500	1,500
Gross Weight (lb)	1,391	1,391



Part No.	TMRC59648F	TMQRC59648F
Finish	Standard	Nitrided
Comes with Leg	6x TMLC30	6x TMLC30
Table Surface Height (in)	33.3 ~ 43.3	33.3 ~ 43.3
Capacity / Leg (lb)	650	650
Gross Weight (lb)	1,425	1,425

## MAX, 8' X 4' TABLETOPS



Part No.	Finish	Dimension (in)	Gross Weight (lb)
TM59648V	Standard	96 x 48	1,286
TMQ59648V	Nitrided	96 x 48	1,286

## INDIVIDUAL PLATES

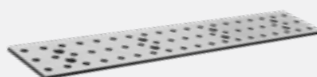

Part No.	Finish	Dimension (in)	Weight (lb)	Thickness (in)
TM59648V-01	Standard	48 x 6	45	5/8
TMQ59648V-01	Nitrided	48 x 6	45	



## TABLE SURFACE DIMENSION: 72" X 48" (ACTUAL)

*\*All load capacities below are calculated based on static load.*

# MAX



Part No.	TMA57248F	TMB57248F	TMQA57248F	TMQB57248F
<b>Finish</b>	Standard	Standard	Nitrided	Nitrided
<b>Comes with Leg</b>	6xTML3130	6xTML2530	6xTML3130	6xTML2530
<b>Table Surface Height (in)</b>	36.5	30.5	36.5	30.5
<b>Capacity / Leg (lb)</b>	1,500	1,500	1,500	1,500
<b>Gross Weight (lb)</b>	1,069	1,057	1,069	1,057



Part No.	TMR57248F	TMQR57248F
<b>Finish</b>	Standard	Nitrided
<b>Comes with Leg</b>	6xTMLR30	6xTMLR30
<b>Table Surface Height (in)</b>	28.5 ~ 38.5	28.5 ~ 38.5
<b>Capacity / Leg (lb)</b>	1,500	1,500
<b>Gross Weight (lb)</b>	1,090	1,090



Part No.	TMRC57248F	TMQRC57248F
<b>Finish</b>	Standard	Nitrided
<b>Comes with Leg</b>	6xTMLC30	6xTMLC30
<b>Table Surface Height (in)</b>	33.3 ~ 43.3	33.3 ~ 43.3
<b>Capacity / Leg (lb)</b>	650	650
<b>Gross Weight (lb)</b>	1,124	1,124



### MAX, 6' X 4' TABLETOPS

Part No.	Finish	Dimension (in)	Gross Weight (lb)
TM57248V	Standard	72 x 48	985
TMQ57248V	Nitrided	72 x 48	985

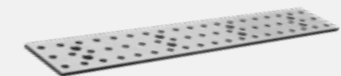

### INDIVIDUAL PLATES

Part No.	Finish	Dimension (in)	Weight (lb)	Thickness (in)
TM59648V-01	Standard	48 x 6	45	5/8
TMQ59648V-01	Nitrided	48 x 6	45	

# 5' X 3' TABLES

U.S. PAT. 8065967



## TABLE SURFACE DIMENSION: 60" X 36" (ACTUAL)

\*All load capacities below are calculated based on static load.



Part No.	TMA56036F	TMB56036F	TMQA56036F	TMQB56036F
Finish	Standard	Standard	Nitrided	Nitrided
Comes with Leg	6xTML3130	6xTML2530	6xTML3130	6xTML2530
Table Surface Height (in)	36.5	30.5	36.5	30.5
Capacity / Leg (lb)	1,500	1,500	1,500	1,500
Gross Weight (lb)	734	722	734	722



Part No.	TMR56036F	TMQR56036F
Finish	Standard	Nitrided
Comes with Leg	6xTMLR30	6xTMLR30
Table Surface Height (in)	28.5 ~ 38.5	28.5 ~ 38.5
Capacity / Leg (lb)	1,500	1,500
Gross Weight (lb)	755	755



Part No.	TMRC56036F	TMQRC56036F
Finish	Standard	Nitrided
Comes with Leg	6xTMLC30	6xTMLC30
Table Surface Height (in)	33.3 ~ 43.3	33.3 ~ 43.3
Capacity / Leg (lb)	650	650
Gross Weight (lb)	789	789

## MAX, 5' X 3' TABLETOPS



Part No.	Finish	Dimension (in)	Gross Weight (lb)
TM56036V	Standard	60 x 36	650
TMQ56036V	Nitrided	60 x 36	650

## INDIVIDUAL PLATES

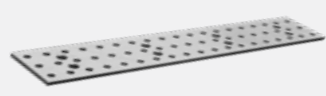

Part No.	Finish	Dimension (in)	Weight (lb)	Thickness (in)
TM56036V-01	Standard	36 x 6	34	5/8
TMQ56036V-01	Nitrided	36 x 6	34	

## TABLE SURFACE DIMENSION: 48" X 48" (ACTUAL)

\*All load capacities below are calculated based on static load.

# MAX



Part No.	TMA54848F	TMB54848F	TMQA54848F	TMQB54848F
<b>Finish</b>	Standard	Standard	Nitrided	Nitrided
<b>Comes with Leg</b>	4xTML3130	4xTML2530	4xTML3130	4xTML2530
<b>Table Surface Height (in)</b>	36.5	30.5	36.5	30.5
<b>Capacity / Leg (lb)</b>	1,500	1,500	1,500	1,500
<b>Gross Weight (lb)</b>	720	710	720	710



Part No.	TMR54848F	TMQR54848F
<b>Finish</b>	Standard	Nitrided
<b>Comes with Leg</b>	4xTMLR30	4xTMLR30
<b>Table Surface Height (in)</b>	28.5 ~ 38.5	28.5 ~ 38.5
<b>Capacity / Leg (lb)</b>	1,500	1,500
<b>Gross Weight (lb)</b>	728	728



Part No.	TMRC54848F	TMQRC54848F
<b>Finish</b>	Standard	Nitrided
<b>Comes with Leg</b>	4xTMLC30	4xTMLC30
<b>Table Surface Height (in)</b>	33.3 ~ 43.3	33.3 ~ 43.3
<b>Capacity / Leg (lb)</b>	650	650
<b>Gross Weight (lb)</b>	750	750



## MAX, 4' X 4' TABLETOPS

Part No.	Finish	Dimension (in)	Gross Weight (lb)
TM54848V	Standard	48 x 48	658
TMQ54848V	Nitrided	48 x 48	658

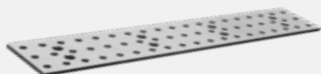

## INDIVIDUAL PLATES

Part No.	Finish	Dimension (in)	Weight (lb)	Thickness (in)
TM59648V-01	Standard	48 x 6	45	5/8
TMQ59648V-01	Nitrided	48 x 6	45	

# 8' X 4' TABLES

U.S. PAT. 8065967

## TABLE SURFACE DIMENSION: 94" X 46" (ACTUAL)

\*All load capacities below are calculated based on static load.

**SLOTTED**



Part No.	TMA59446	TMB59446	TMQA59446	TMQB59446
<b>Finish</b>	Standard	Standard	Nitrided	Nitrided
<b>Comes with Leg</b>	6xTML3130	6xTML2530	6xTML3130	6xTML2530
<b>Table Surface Height (in)</b>	36.5	30.5	36.5	30.5
<b>Capacity / Leg (lb)</b>	1,500	1,500	1,500	1,500
<b>Gross Weight (lb)</b>	1,048	1,036	1,048	1,036



Part No.	TMR59446	TMQR59446
<b>Finish</b>	Standard	Nitrided
<b>Comes with Leg</b>	6xTMLR30	6xTMLR30
<b>Table Surface Height (in)</b>	28.5 ~ 38.5	28.5 ~ 38.5
<b>Capacity / Leg (lb)</b>	1,500	1,500
<b>Gross Weight (lb)</b>	1,069	1,069



Part No.	TMRC59446	TMQRC59446
<b>Finish</b>	Standard	Nitrided
<b>Comes with Leg</b>	6xTMLC30	6xTMLC30
<b>Table Surface Height (in)</b>	33.3 ~ 43.3	33.3 ~ 43.3
<b>Capacity / Leg (lb)</b>	650	650
<b>Gross Weight (lb)</b>	1,103	1,103

## SLOTTED, 8' X 4' TABLETOPS



Part No.	Finish	Dimension (in)	Gross Weight (lb)
TM59446SV	Standard	94 x 46	964
TMQ59446SV	Nitrided	94 x 46	964

## INDIVIDUAL PLATES

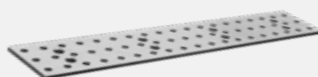

Part No.	Finish	Dimension (in)	Weight (lb)	Thickness (in)
TM57846SV-01	Standard	46 x 6.3	48	5/8
TMQ57846SV-01	Nitrided	46 x 6.3	48	



## TABLE SURFACE DIMENSION: 78" X 46" (ACTUAL)

*\*All load capacities below are calculated based on static load.*

# SLOTTED



Part No.	TMA57846	TMB57846	TMQA57846	TMQB57846
<b>Finish</b>	Standard	Standard	Nitrided	Nitrided
<b>Comes with Leg</b>	6xTML3130	6xTML2530	6xTML3130	6xTML2530
<b>Table Surface Height (in)</b>	36.5	30.5	36.5	30.5
<b>Capacity / Leg (lb)</b>	1,500	1,500	1,500	1,500
<b>Gross Weight (lb)</b>	906	894	906	894



Part No.	TMR57846	TMQR57846
<b>Finish</b>	Standard	Nitrided
<b>Comes with Leg</b>	6xTMLR30	6xTMLR30
<b>Table Surface Height (in)</b>	28.5 ~ 38.5	28.5 ~ 38.5
<b>Capacity / Leg (lb)</b>	1,500	1,500
<b>Gross Weight (lb)</b>	927	927



Part No.	TMRC57846	TMQRC57846
<b>Finish</b>	Standard	Nitrided
<b>Comes with Leg</b>	6xTMLC30	6xTMLC30
<b>Table Surface Height (in)</b>	33.3 ~ 43.3	33.3 ~ 43.3
<b>Capacity / Leg (lb)</b>	650	650
<b>Gross Weight (lb)</b>	961	961

## SLOTTED, 6-1/2' X 4' TABLETOPS

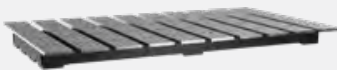

Part No.	Finish	Dimension (in)	Gross Weight (lb)
TM57846SV	Standard	78 x 46	822
TMQ57846SV	Nitrided	78 x 46	822

## INDIVIDUAL PLATES

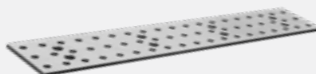

Part No.	Finish	Dimension (in)	Weight (lb)	Thickness (in)
TM57846SV-01	Standard	46 x 6.3	48	5/8
TMQ57846SV-01	Nitrided	46 x 6.3	48	

## 6-1/2' X 3' TABLES

U.S. PAT. 8065967

### TABLE SURFACE DIMENSION: 78" X 38" (ACTUAL)

\*All load capacities below are calculated based on static load.

**SLOTTED**



Part No.	TMA57838	TMB57838	TMQA57838	TMQB57838
Finish	Standard	Standard	Nitrided	Nitrided
Comes with Leg	6xTML3130	6xTML2530	6xTML3130	6xTML2530
Table Surface Height (in)	36.5	30.5	36.5	30.5
Capacity / Leg (lb)	1,500	1,500	1,500	1,500
Gross Weight (lb)	819	807	819	807



Part No.	TMR57838	TMQR57838
Finish	Standard	Nitrided
Comes with Leg	6xTMLR30	6xTMLR30
Table Surface Height (in)	28.5 ~ 38.5	28.5 ~ 38.5
Capacity / Leg (lb)	1,500	1,500
Gross Weight (lb)	840	840



Part No.	TMRC57838	TMQRC57838
Finish	Standard	Nitrided
Comes with Leg	6xTMLC30	6xTMLC30
Table Surface Height (in)	33.3 ~ 43.3	33.3 ~ 43.3
Capacity / Leg (lb)	650	650
Gross Weight (lb)	874	874

### SLOTTED, 6-1/2' X 3' TABLETOPS



Part No.	Finish	Dimension (in)	Gross Weight (lb)
TM57838SV	Standard	78 x 38	735
TMQ57838SV	Nitrided	78 x 38	735

### INDIVIDUAL PLATES

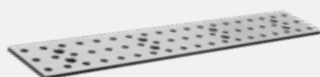

Part No.	Finish	Dimension (in)	Weight (lb)	Thickness (in)
TM57838SV-01	Standard	38 x 6.3	40	5/8
TMQ57838SV-01	Nitrided	38 x 6.3	40	

## TABLE SURFACE DIMENSION: 47" X 46" (ACTUAL)

\*All load capacities below are calculated based on static load.

# SLOTTED



Part No.	TMA54746	TMB54746	TMQA54746	TMQB54746
<b>Finish</b>	Standard	Standard	Nitrided	Nitrided
<b>Comes with Leg</b>	4xTML3130	4xTML2530	4xTML3130	4xTML2530
<b>Table Surface Height (in)</b>	36.5	30.5	36.5	30.5
<b>Capacity / Leg (lb)</b>	1,500	1,500	1,500	1,500
<b>Gross Weight (lb)</b>	548	540	548	540



Part No.	TMR54746	TMQR54746
<b>Finish</b>	Standard	Nitrided
<b>Comes with Leg</b>	4xTMLR30	4xTMLR30
<b>Table Surface Height (in)</b>	28.5 ~ 38.5	28.5 ~ 38.5
<b>Capacity / Leg (lb)</b>	1,500	1,500
<b>Gross Weight (lb)</b>	562	562



Part No.	TMRC54746	TMQRC54746
<b>Finish</b>	Standard	Nitrided
<b>Comes with Leg</b>	4xTMLC30	4xTMLC30
<b>Table Surface Height (in)</b>	33.3 ~ 43.3	33.3 ~ 43.3
<b>Capacity / Leg (lb)</b>	650	650
<b>Gross Weight (lb)</b>	585	585



## SLOTTED, 4' X 4' TABLETOPS

Part No.	Finish	Dimension (in)	Gross Weight (lb)
TM54746SV	Standard	47 x 46	492
TMQ54746SV	Nitrided	47 x 46	492

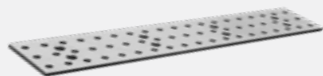

## INDIVIDUAL PLATES

Part No.	Finish	Dimension (in)	Weight (lb)	Thickness (in)
TM57846SV-01	Standard	46 x 6.3	48	5/8
TMQ57846SV-01	Nitrided	46 x 6.3	48	

# 4' X 3' TABLES

U.S. PAT. 8065967

## TABLE SURFACE DIMENSION: 47" X 38" (ACTUAL)

\*All load capacities below are calculated based on static load.

**SLOTTED**



Part No.	TMA54738	TMB54738	TMQA54738	TMQB54738
<b>Finish</b>	Standard	Standard	Nitrided	Nitrided
<b>Comes with Leg</b>	4xTML3130	4xTML2530	4xTML3130	4xTML2530
<b>Table Surface Height (in)</b>	36.5	30.5	36.5	30.5
<b>Capacity / Leg (lb)</b>	1,500	1,500	1,500	1,500
<b>Gross Weight (lb)</b>	501	493	501	493



Part No.	TMR54738	TMQR54738
<b>Finish</b>	Standard	Nitrided
<b>Comes with Leg</b>	4xTMLR30	4xTMLR30
<b>Table Surface Height (in)</b>	28.5 ~ 38.5	28.5 ~ 38.5
<b>Capacity / Leg (lb)</b>	1,500	1,500
<b>Gross Weight (lb)</b>	515	515



Part No.	TMRC54738	TMQRC54738
<b>Finish</b>	Standard	Nitrided
<b>Comes with Leg</b>	4xTMLC30	4xTMLC30
<b>Table Surface Height (in)</b>	33.3 ~ 43.3	33.3 ~ 43.3
<b>Capacity / Leg (lb)</b>	650	650
<b>Gross Weight (lb)</b>	538	538



### SLOTTED, 4' X 3' TABLETOPS

Part No.	Finish	Dimension (in)	Gross Weight (lb)
TM54738SV	Standard	47 x 38	445
TMQ54738SV	Nitrided	47 x 38	445

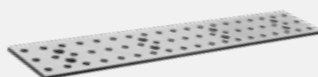

### INDIVIDUAL PLATES

Part No.	Finish	Dimension (in)	Weight (lb)	Thickness (in)
TM57838SV-01	Standard	38 x 6.3	40	5/8
TMQ57838SV-01	Nitrided	38 x 6.3	40	



## TABLE SURFACE DIMENSION: 22" X 38" (ACTUAL)

\* 2' x 4' Tables are also available. Please check [buildprotables.com](http://buildprotables.com) for details.

\*All load capacities below are calculated based on static load.

# SLOTTED



Part No.	TMA52238	TMB52238	TMQA52238	TMQB52238
Finish	Standard	Standard	Nitrided	Nitrided
Comes with Leg	4xTML3130	4xTML2530	4xTML3130	4xTML2530
Table Surface Height (in)	36.5	30.5	36.5	30.5
Capacity / Leg (lb)	1,500	1,500	1,500	1,500
Gross Weight (lb)	306	278	306	278



Part No.	TMR52238	TMQR52238
Finish	Standard	Nitrided
Comes with Leg	4xTMLR30	4xTMLR30
Table Surface Height (in)	28.5 ~ 38.5	28.5 ~ 38.5
Capacity / Leg (lb)	1,500	1,500
Gross Weight (lb)	320	320



Part No.	TMRC52238	TMQRC52238
Finish	Standard	Nitrided
Comes with Leg	4xTMLC30	4xTMLC30
Table Surface Height (in)	33.3 ~ 43.3	33.3 ~ 43.3
Capacity / Leg (lb)	650	650
Gross Weight (lb)	343	343



## SLOTTED, 2' X 3' TABLETOPS

Part No.	Finish	Dimension (in)	Gross Weight (lb)
TM52238SV	Standard	22 x 38	250
TMQ52238SV	Nitrided	22 x 38	250

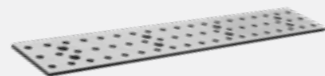

## INDIVIDUAL PLATES

Part No.	Finish	Dimension (in)	Weight (lb)	Thickness (in)
TM57838SV-01	Standard	38 x 6.3	40	5/8
TMQ57838SV-01	Nitrided	38 x 6.3	40	



**TABLE PLATE MOUNTING KITS**

- For Alpha 5/8 tables

8 pc. of M12 screws for mounting table top or side plates to the table frame.



\* This kit is designed for Alpha 5/8 tables only.

Part No.	Description	Weight (lb)
TY5-M12-8K	8x M12 Mounting Screws	0.6

- For MAX tables

The kit includes 10 pc. of 0.866" O.D. locating bushings and 10 pc. of M10 x 22 mounting screws.

Locating Bushings allow you to remove, re-position, re-align, and reverse the table plates! Must be used in conjunction with mounting screws.

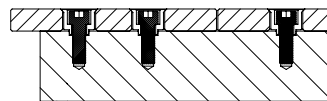
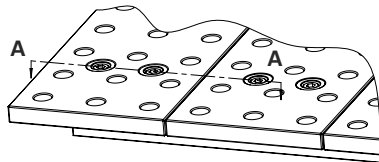

SECTION A-A

Part No.	Description	Weight (lb)
TM62010-04-10K	10x Locating Bushing + 10x Mounting Screws	1.1

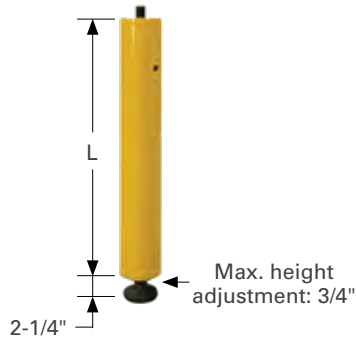

## HEAVY DUTY TABLE LEGS

These legs feature steel leveling pads to ensure proper leveling of your table on uneven surfaces. They create a comfortable, safe working height just for you.

Part No.	Dia. (in)	Thread	Leg Height - L (in)	* L + Leveling Pad Height (in)	Weight (lb)
TML3130	3	M20	28	30.3	13
TML2530	3	M20	22	24.3	11

\* Table Leg + Leveling Pad height is based on Leveling Pad height of 2-1/4".

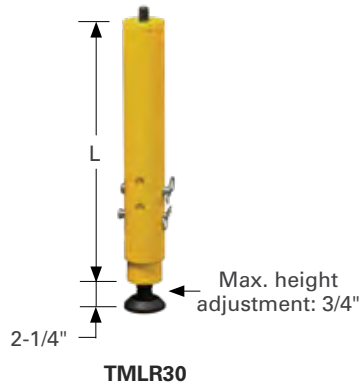

## ADJUSTABLE LEGS

Adjustable at 1" increments. Telescoping adjustable range (L) from 20" to 30" in height.

Part No.	Description	Dia. (in)	Leg Adjustable Range - L (in)	L + Leveling Pad / Caster Height (in)	Weight (lb)
TMLR30	Adjustable Leg	3	20 ~ 30	22.3 ~ 32.3	16.5
TMLC30	Adjustable Leg with caster	3	20 ~ 30	27 ~ 37	22.2



## SUPPORT LEG ADAPTER

Use the Support Leg Adapter + a BuildPro® Table Leg (M20 thread) to support extended table plates at the uniform table height. Screw the table leg into the threaded base of the Support Leg Adapter. Attach the Support Leg Adapter and Leg assembly to the extended table plate using two flush mount socket head shoulder screws (included with Leg Adapter).

Part No.	Description	Dia. (in)	Weight (lb)
TMLA7	Leg Adapter to support plate extensions and reconfigurations. <i>(Legs sold separately.)</i>	2.8	6

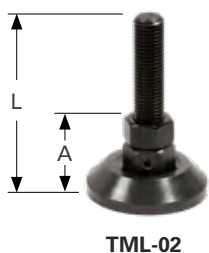

## LEVELING PAD

Add Leveling Pad Feet to your BuildPro® Tabletop to create a low height table.

Maximum height adjustment: 3/4".

Part No.	L (in)	A (in)	Base Dia. (in)	Thread	Pitch (mm)	Weight (lb)
TML-02	4.8	2.3	3	M20	2.5	1.8

## TABLE ACCESSORIES

### LEVELING CASTER



These compact, heavy duty leveling casters are the simple way to move and level your BuildPro® Welding Table.

**This caster will add 3" to your total tabletop surface height.**

*\* Sold individually.*

Part No.	Capacity (lb)	Thread	Weight (lb)
TMLC600	1,100 each	M20	4.3

### MOBILITY CASTER

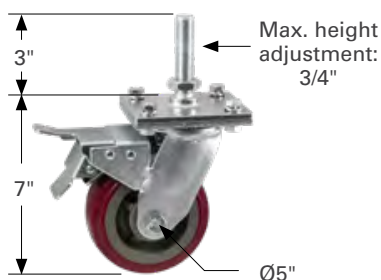

Durable caster rolls smoothly on precision ball bearings, with non-marking, non-marring nylon polymer wheels. Dual toe-step braking system can be set for "no-swivel + no-roll".

**This caster will add 5-3/4" to your total tabletop surface height.**

*\* Sold individually.*

Part No.	Capacity (lb)	Thread	Weight (lb)
TMLC700	650 each	M20	7.8

### LEG BRACES

Fit all 3" diameter legs. Leg Braces reinforce and stabilize the BuildPro® table.

Ideal as a base for creating shelves. Place a metal plate or wooden board on the brace framework. Create one, or multiple level shelves with additional Leg Brace Assembly.



Part No.	Leg Brace Assembly for		Weight (lb)
	Table	Table Size (ft)	
TMLB120A	Alpha	10 x 5	32
TMLB96A		8 x 4	31
TMLB72A		6 x 4	23
TMLB70A		6 x 3	20
TMLA48A		4 x 4	15
TMLB96	MAX	8 x 4	31
TMLB72		6 x 4	23
TMLB70		6 x 3	20
TMLB60		5 x 3	22
TMLB48		4 x 4	15
TMLB94	Slotted	8 x 4	28
TMLBR78		6.5 x 3 and 6.5 x 4	25
TMLBR47		4 x 3 and 4 x 4	15
TMLBR22		2 x 3 and 2 x 4	13



**BUILDPRO®**

Welding Tables



## RHINO CART OVERVIEW

Quickly clamp and fixture at any point on the surface. Accurately setup stock for each new project.

- Surface ground for flatness on both sides and reversible
- Heat Treated (Nitrided) for wear and spatter resistance



StrongHand Tools  
**RHINO CART™**  
MOBILE FIXTURING STATION



U.S. PAT. 9896117

Tabletop Size:	48" x 30"
Top Plate Thickness:	0.630" ±0.004
Tabletop Flatness:	±0.015" per 24" x 24"
Hole Diameter:	5/8"
Grid Pattern:	2" x 2"
Table Height:	36"
Static Loading Capacity:	1,500 lb



## RHINO CART OVERVIEW

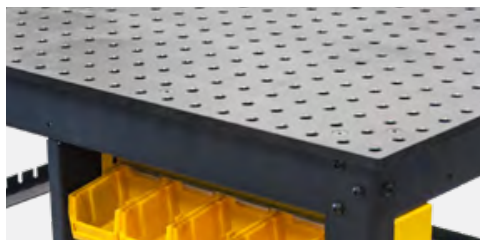

### Reversible Tabletop

Nitrided and black oxide table plate is **REVERSIBLE**. Weld spatter, rust and scratch resistant.

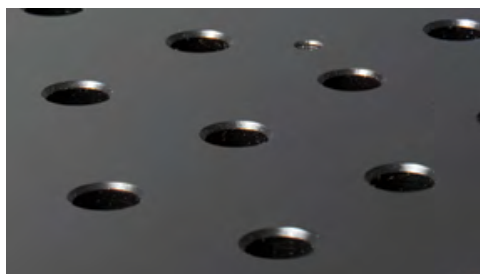

### CNC Hole Pattern

Accurately position parts in CNC precision bored 5/8" diameter holes in 2" x 2" spacing pattern.



### Locking Casters

Steel legs are equipped with 2x locking casters + 2x leveling feet for mobile or stationary use.



### Store & Organize

Shelves, racks, and a pegboard panel allow you to store, organize, and keep clamps and accessories within reach.



### Additional Accessories (sold separately)

Attach the fold-up Plasma Cutting Tray or Hitch Mount Plate to your Rhino Cart® Mobile Fixturing Station to cut, clamp, fixture and weld on one convenient workstation.



### Compatible with 5/8" Fixturing Elements

The Rhino Cart® Tabletop is compatible with all BuildPro® Clamps, Components, and Modular Fixturing Kits *except Sliding Channel Clamps, Sliding Channel Bases, Slot filler Kit and T-Slot Adapter.*

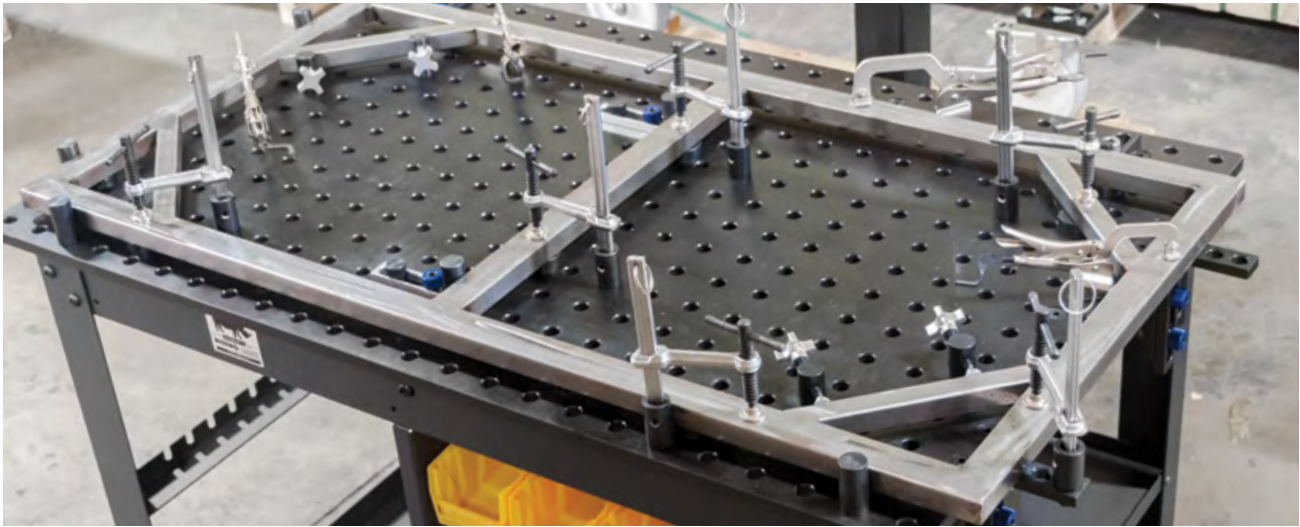

Part No.	Description	Gross Weight (lb)
TD5-4830Q-K1	Rhino Cart + 66 pc. Fixture Kit (TD5-4830Q-F1 + TDK5100)	510
TD5-4830Q-F1	Rhino Cart	490
TD5-4830Q	Tabletop Only	276
TD5-4830Q-N	Tabletop w/ Frame	328

# RHINO CART ACCESSORIES

## PLASMA CUTTING TRAY



TPL3021

The Plasma Cutting Tray supports 100 lb, on a 18" x 28" cutting surface with 14 reversible / replaceable steel slats. Generous 1.8" width between cutting slats provides ample space for hold-down clamping. The fold-out Plasma Cutting Tray easily folds down flat against the Rhino Cart® when not in use. Slats remain secured in place when tray is folded.



Cut, clamp and fixture on one convenient mobile work station at the ideal, uniform working height.



\* This accessory is designed for Rhino Cart only.



TPLK3021

Part No.	Cutting Area (in)	Holding Capacity (lb)	Weight (lb)
TPL3021	18 x 28	100	33
TPLK3021	14 Reversible / Replaceable Slats		10



## HITCH MOUNT PLATE



Mount under the Rhino Cart® table with flush mount screws (included) to create a firm, stable platform to mount your equipments.

Accommodates a three or four hole mounting base pattern.



\* This accessory is designed for Rhino Cart only.

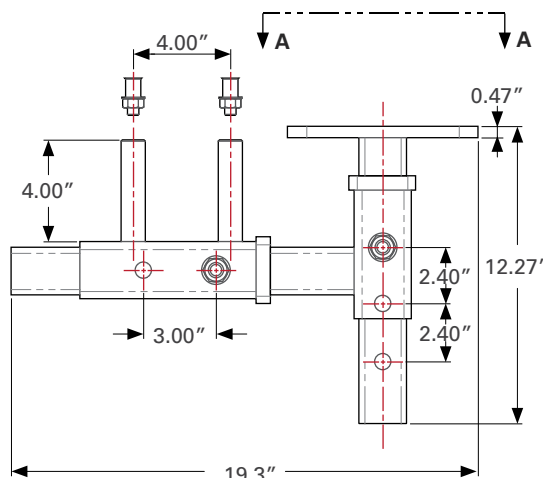
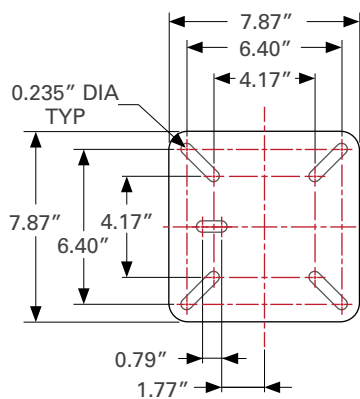

Part No.	Weight (lb)
TXH8022	24



\* Vises not included.





**KICK-TURN TABLE**  
TKT4020

**HAND-TURN TABLE**  
THT4020

The BuildPro turntables are a must-have for anyone doing precision rotary welding.

Designed to mount directly onto the Rhino Cart and provides height and tilt adjustment while allowing complete 360° rotary positioning.

The 20" x 20" work platform comprises of a lightweight aluminum plate with Ø5/8" fixturing boreholes.

Model TKT4020 has an attached kick carousel that allows rotation control using foot operation.

- 0°, 15°, 30° and 45° tilt
- 360° rotation with position locking at every 45°
- Height Adjustment: 2" / Extends: 3"
- Built-in grounding point
- 55 lb. loading capacity

**Material:** Aluminum  
**Tabletop Size:** 20" x 20"  
**Top Plate Thickness:** 0.472"  
**Hole Diameter:** 5/8"  
**Grid Pattern:** 2" x 2"  
**Static Loading Capacity:** 55 lb

\* For steel tabletop, please contact our sales team [sales@stronghandtools.com](mailto:sales@stronghandtools.com).

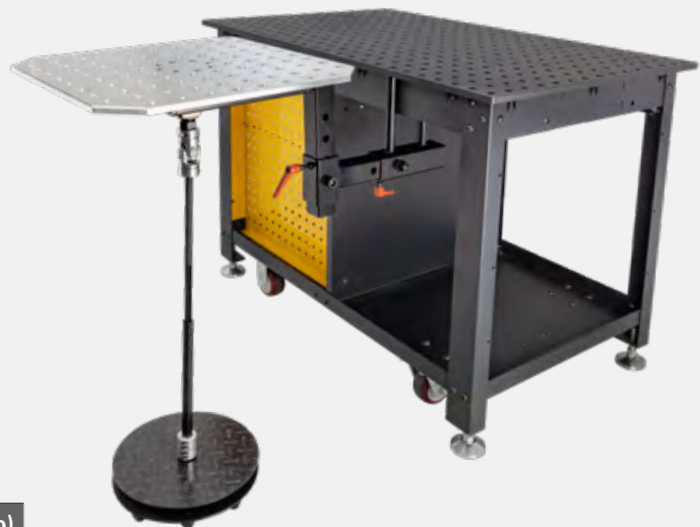

\* This accessory is designed for Rhino Cart only.  
 \* Rhino Cart NOT included.

Part No.	Description	L x H (in)	Weight (lb)
THT4020	Hand-turn Table	33.1 x 16	44
TKT4020	Kick-turn Table	33.1 x 31.4	55



0°, 15°, 30° and 45° tilt



Position locking at every 45°



Height adjustment: 2"  
Extends: 3"



Built-in grounding point

# MANIPULATOR



The manipulator uses two rotating axis and one tilting axis to position your work in the ideal spot. For best results, always position the center of gravity of the work piece in line with the two rotating axis to achieve low resistance repositioning.

- Access difficult joints without putting yourself in an awkward position
- Position the joint for fastest technique. Go from vertical up or overhead to a flat or downhill weld. Get the job finished with less mental and physical fatigue.
- Fast repositioning. No need to un-clip.

*\* We also offer a 30-pc. fixturing kit (TUK5300) to make your set up on the new manipulator fast and accurate, minimize variables for repeat jobs. See pg. 70 for kit details.*

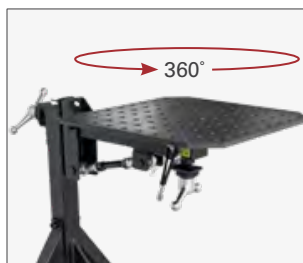

Horizontal Rotary Axis



Vertical Rotary Axis



15° fine adjustment



Spring loaded carbon brush grounds rotating plate to stationary grounding point.



Three Locking Positions - 0° and 30° on both sides.



Two large handles for quick & easy adjustment of rotary axis



Two casters for quick repositioning of manipulator.



Large leveling pads with wrench flats

Part No.	H x L x W (in)	Top Plate Size (in)	Hole Dia. (in)	Capacity (lb)	Gross Weight (lb)
TU52020	40 x 37 x 37	20 x 20 x 15/32	5/8	110	226



# ROTARY POSITIONERS

Mount your BuildPro® or Alpha 28 Welding Tabletop to the BuildPro® Rotary Positioner for plane rotation of your work surface. The low backlash gear drive allows for smooth operation, stability, and controlled turning and positioning.

The worm gears combined with center of gravity positioning minimizes the effort required for rotation while preventing free rotation of the table from gravity. A faceplate with 15° increments provides positive manual locking. The BuildPro® Rotary Positioner allows you to rotate your weld fixture to the best ergonomic position for worker safety, comfort, and reduced operator fatigue.

The BuildPro® Rotary Positioner is universal, with an adjustable base to accommodate most standard BuildPro® or Alpha 28 Welding Tabletops. The Positioner features four swiveling, locking casters, and four leveling feet for setup at dedicated or alternating locations in the shop.

\* Positioner Capacity: 2,400 lb.



\*Tabletop sold separately.

Table Mounting Brackets

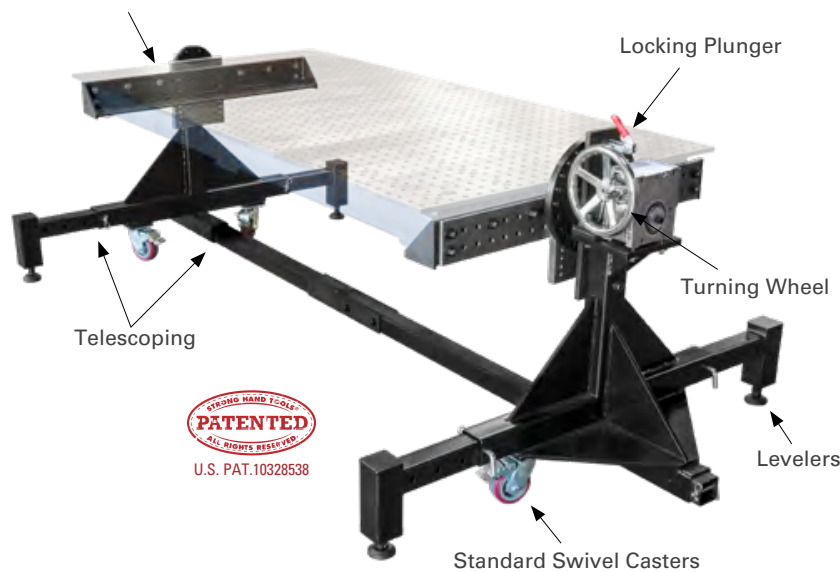

\* Positioners are designed for MAX and Slotted tables; for Alpha 28 and 5/8 applications, please contact our sales team: [sales@stronghandtools.com](mailto:sales@stronghandtools.com)

# ROTARY POSITIONERS



Our new adjustable outriggers allow greater stability when working with taller assemblies and can be retracted when not required.

Adjustment plates help shift the center of gravity in 1" increments when working with tall or heavy parts. This allows smoother rotation of assemblies up to 90° from horizontal.

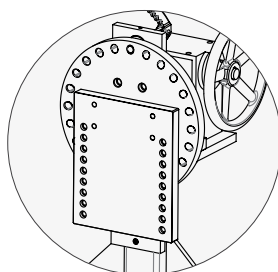

Adjustment plates included.

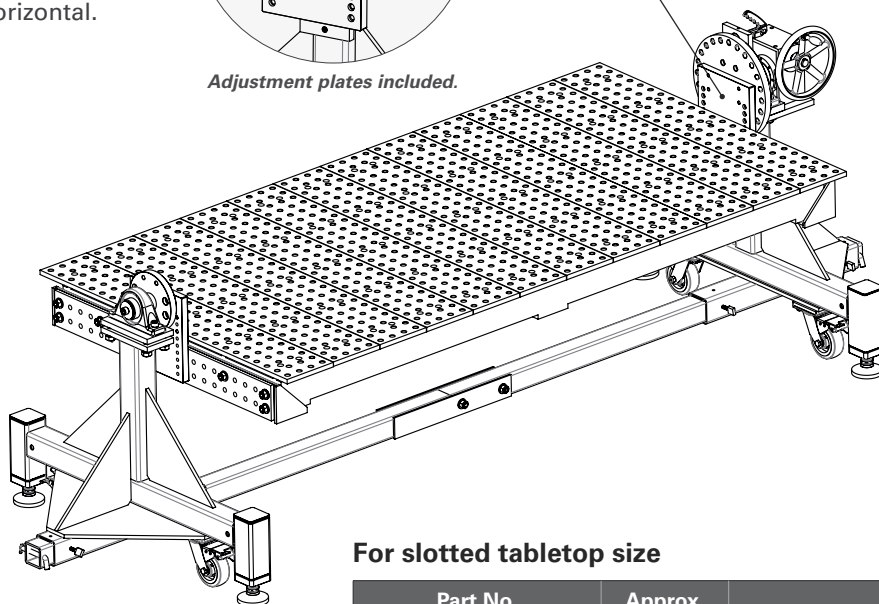

## For MAX tabletop size

Part No. (Positioner + Mounting Brackets)	Approx. Weight (lb)	(For Use w/ Tabletop)
TMP59648	1,100	TM(Q)59648V (8' x 4')
TMP57248	1,054	TM(Q)57248V (6' x 4')
TMP56036	1,000	TM(Q)56036V (5' x 3')
TMP54848	1,030	TM(Q)54848V (4' x 4')

## For slotted tabletop size

Part No. (Positioner + Mounting Brackets)	Approx. Weight (lb)	(For Use w/ Tabletop)
TMP59446	1,024	TM(Q)59446SV (8' x 4')
TMP57846	1,010	TM(Q)57846SV (6.5' x 4')
TMP57838	1,010	TM(Q)57838SV (6.5' x 3')
TMP54746	988	TM(Q)54746SV (4' x 4')
TMP54738	988	TM(Q)54738SV (4' x 3')

\*All tabletop sold separately.





(TMP52418 shown)

**Mount on any of the 5/8 Welding Tabletops. Allow you to rotate your weld fixture to the best ergonomic position for worker safety, comfort, and reduced operator fatigue.**

Capacity: 300 lb.

The Mini Rotary Positioners are universal, with mounting bolt pattern to accommodate the Alpha 5/8, MAX and Rhino Cart Welding Tabletops.

They can be an important addition to your tool chest allowing you to rotate assemblies easily without having to wait until they cool.

The worm gears combined with center of gravity positioning reduces the effort required for rotation while preventing free rotation of the table from gravity.

A faceplate with 15° increments provides positive manual locking.

Axis point to mounting base is 13-1/2".



TMP52418TS



TMP52418T

Part No.	Description	H x L x W (in)	Approx. Weight (lb)
TMP52418	Mini Positioner with Tomb Stone Sub Assembly - Fixturing Plate (approx. 24" x 18" x 0.6") Included	42 x 18 x 24	310
TMP52418TS	Mini Positioner with Tomb Stone Sub Assembly - No Fixturing Plate	19 x 15 x 24	210
TMP52418T	Mini Positioner Body only	18 x 15 x 24	178



# LIFT PLATFORMS

## STATIONARY SCISSOR LIFT PLATFORMS



New Stationary Scissor Lifts increase productivity and worker comfort by setting your BuildPro® table at the ideal height for each project.

Quick-acting scissor lift platform raises loads up to 4,200 lb to from a range of 8.5" - 48" in height.

The large push button power control is operated by hand. Chip resistant powder coated finish.

Meets ANSI standards for Lift Tables.  
\* Mounting Hardware Included.

Part No.	Fits Tabletops	Travel (in)	Capacity (lb)	Platform Size (in)	Platform Height* (in)		Voltage	Approx. Time (sec.)		Approx. Weight (lb)
					Lowered	Raised		Up	Down	
TMLK2-3648	TM(Q)54738SV	30	1,500	36 x 48	8.5	38.5	115 VAC	24	12	455
TMLK3-3648	TM(Q)54746SV	34	2,500	36 x 48	8.7	42.6	115 VAC	25	12	560
TMLK5-4872	TM(Q)57846SV	39	4,200	48 x 72	8.8	48.0	115 VAC	50	24	1,030

\* Platform height without tabletop.

## HD ERGONOMIC HEIGHT-ADJUSTABLE ELECTRIC ACTUATED LIFT PLATFORM



\* Tabletop sold separately.

\* Patented design. Built in the U.S.A.

This strong, rigid, vibration dampening platform operates smoothly with the use of a programmable switch.

Constructed from 11 / 14 ga thick steel columns with laser cut, welded horizontal supports made of 1/2" steel plates.

Lock in the stationary position, or roll to desired location on 5" casters. Durable powder coated finish.

\* Contact our Sales Team: [sales@stronghandtools.com](mailto:sales@stronghandtools.com) for other sizes.

Part No.	Fits BuildPro Max 8' x 4' Tabletop	Travel (in)	Capacity (lb)	Platform Size (in)	Platform Height* (in)		Voltage	Approx. Time (sec.)		Approx. Weight (lb)
					Lowered	Raised		Up	Down	
TMLT9648	TM(Q)59648V	12.5	6,500	96 x 48	28.5	41	115 VAC	40	40	600

\* Platform height without tabletop.

# KEY ELEMENTS IN THE BUILDPRO® MODULAR FIXTURING SYSTEM

## NEW DESIGN



**Ball Lock Bolt**  
- An essential component in Modular Fixturing!



Finger tighten the knurled head after insertion to preload before tightening with Hex Key.

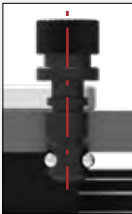

Three locking steel balls move outward to lock the bolt in position.

**Ball Lock Bolts** are key to the efficient set up of Modular Fixtures on your BuildPro® Tabletop. Use the Ball Lock Bolts to fasten clamping elements to the BuildPro® Tabletop, or fasten two clamping elements together.

### Basic Hold Down Clamping:

- Inserta Clamps
- Sliding Channel Clamps
- Inserta Pliers
- Good Hand® Toggle Clamps

### Stop, Position, & Locate Stock:

- Right Angle Brackets
- Straight Edge Stops
- Econo Stop & Clamping Squares
- Malleable Cast Iron Clamping Squares
- Heavy Duty Riser Blocks
- Stops, Rests, and V-Blocks

## Clamps



Quick hold-down clamping of flat, square, angled or round parts.

## Support Round Stock

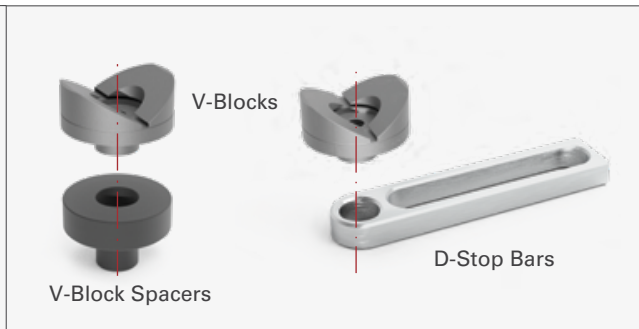

Elevate and hold round parts.

## Locate / Stop

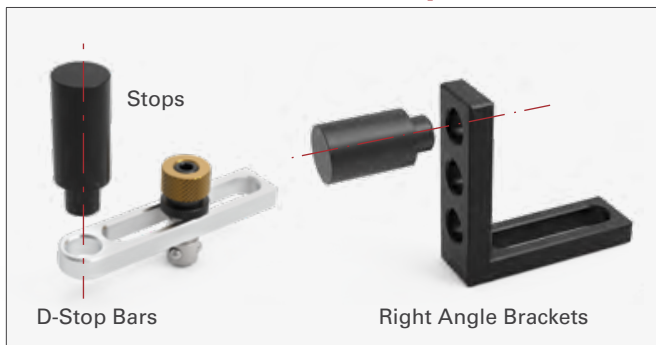

Stop, locate, and position parts.

## Stop / Locate / Elevate

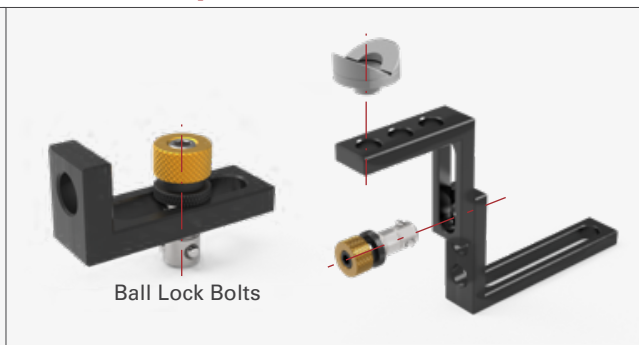

Stop and locate parts.

Stack Right Angle Brackets to elevate and hold round parts.

# CLAMPS

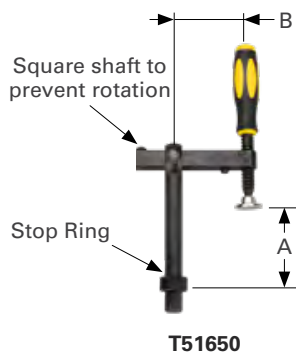

T51650



T51655

## T-POST CLAMPS

Place the Adjustable T-Post Clamp in any of the Ø5/8" (16 mm) holes on the Tabletop or Heavy Duty Riser Blocks for vertical hold down clamping.

Adjust the clamp arm along the vertical or horizontal axis for each unique hold down application. Adjustable arm provides precise clamping location by sliding the spindle to any desired pressure point.

Move the Stop Ring as needed to set the height of the clamp.

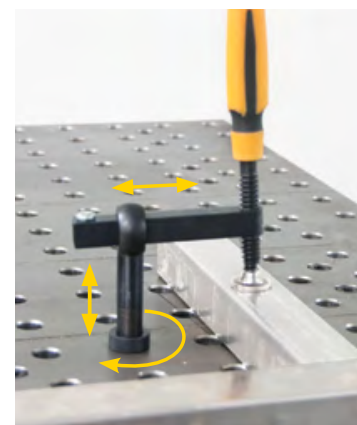

### Fit 5/8" holes

Part No.	Handle	Clamping Capacity A (in)	Throat Depth B (in)	Weight (lb)
T51650	Straight	Max. 4.5	1.8 - 3.3	1.4
T51655	T-Handle	Max. 4.5	1.8 - 3.3	1.4

### Fit 16 mm holes

Part No.	Handle	Clamping Capacity A (mm)	Throat Depth B (mm)	Weight (kg)
T61650	Straight	Max. 114	44.5 - 82.5	0.6

### Multi-Directional

## PIVOTING T-POST CLAMP

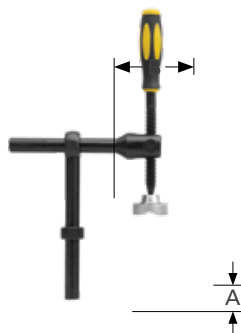

Vertical Clamping

Use the versatile Pivoting T-Post Clamp to apply angled clamping force. Clamp stock horizontally and vertically.

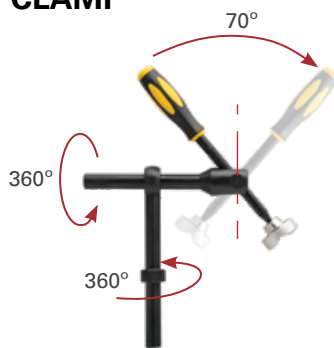

Angled Clamping

For **vertical** hold down clamping, or **angled** clamping, place the fixed Vertical Clamp arm, with Pivoting Spindle, in the clamp post.



Horizontal Clamping

For **horizontal** clamping, remove the fixed Vertical Clamp arm and Pivoting Spindle from the clamp post, and place directly into the tabletop holes.



### Fit 5/8" holes

Part No.	Clamping Capacity A (in)	Throat Depth B (in)	Weight (lb)
T51670	Max. 5.0	1.8 - 5.0	1.8

### Fit 16 mm holes

Part No.	Clamping Capacity A (mm)	Throat Depth B (mm)	Weight (kg)
T61670	Max. 5.0	44.5 - 127	0.8

**INSERTA CLAMPS**

Place the Inserta Clamps into the 5/8" (16 mm) holes on the tabletop and squares for fast, easy clamping. Clamp in the vertical or horizontal position at any height.

The Ratchet Handle Model is ideal for tight space clamping, and the ratchet mechanism ensures rapid, vibration and torsion resistant clamping.

Clip the optional Top V-Pads (pg. 39) onto the top spindle to clamp round or angled stock. Remove the clamp arm by depressing the spring stop, and slide the Sidekick attachment (pg. 39) onto the clamp bar, followed by the clamp arm, for two point horizontal and vertical clamping force.

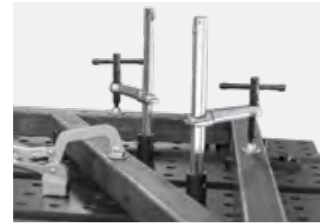

**T-Handle**  
UDN5150 | UEN5200



**Ratchet Handle**  
UERN5200

**Fit 5/8" holes**

Part No.	Clamping Capacity (in)	Throat Depth (in)	Clamping Pressure (lb)	Rail Size (in)	Weight (lb)
UDN5150	6.5	3.3	300	5/8 x 5/16	1.2
UEN5200	8.5	4.0	400	25/32 x 3/8	2.2
UERN5200	8.5	4.0	400	25/32 x 3/8	2.2

**Fit 16 mm holes**

Part No.	Clamping Capacity (mm)	Throat Depth (mm)	Clamping Pressure (kg)	Rail Size (mm)	Weight (kg)
UDN6150	150	83	136	16 x 8	0.5
UEN6200	200	100	181	20 x 10	1.0

**SLIDING CHANNEL CLAMPS \***

The 360° Sliding Channel Clamp slides into the 1.7" spacing between plates which enables the clamp body to slide along the entire surface and swivel 360° for positioning at any point.

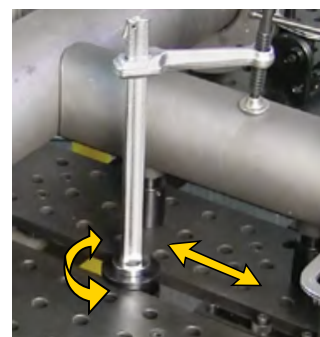

Part No.	Clamping Capacity (in)	Throat Depth (in)	Clamping Pressure (lb)	Rail Size (in)	Weight (lb)
T51405	8.5	4.8	500	7/8 x 7/16	3.5
T51510	12.5	4.8	600	1 x 15/32	4.8
T51615	20.5	5.5	700	1-3/16 x 9/16	8.2

\* Not applicable to slotless tables.

## CLAMP ACCESSORIES

### SIDEKICKS

Slide the Sidekick onto the clamp rail of Inserta Clamps and Sliding Channel Clamps for horizontal clamping force.



Part No.	For Inserta Clamps	For Sliding Channel Clamps	Stroke (in)	Weight (lb)
XDS	UDN5150	--	1	0.6
XFS	--	T51405	1.4	1.2
XGS	--	T51510	1.4	1.2
XMS	--	T51615	1.4	1.2



### V-PADS

Add the Magnetic Top V-Pad onto the swivel pad to hold round, square, flat, and angled stock.

Optional Clip-on Top V-pad clips onto the swivel pad for clamping round parts or 2 parts at once.



\*U.S. PAT. 10307894\*

Alum. Magnetic Top V-Pad  
T54217 | T54219



Clip-on Top V-Pads



Stainless Steel V-Pads  
XDA2S | XFA2S

	Part No.	For Inserta Clamps	For T-Post Clamps	For Sliding Channel Clamps	Weight (lb)
Aluminum	T54217	UDN5150 & UDWN5150	T51650, T51655, T51670	--	0.05
	T54219	UEN5200	--	T51405 & T51510	0.05
Stainless Steel	XDA2	UDN5150 & UDWN5150	T51650, T51655, T51670	--	0.2
	XFA2	UEN5200 & UEWN5200	--	T51405 & T51510	0.4
	XMA2	--	--	T51615	0.6
	XDA2S	UDN5150 & UDWN5150	T51650, T51655, T51670	--	0.2
	XFA2S	UEN5200 & UEWN5200	--	T51405 & T51510	0.4



### MAGNETIC PLUGS

Set of four 1" Magnetic Plug / Rest Button can be used on any flat surface, inserted into the holes on the BuildPro® Table or the holes on BuildPro® Economy Clamping Squares.



Part No.	Description	Weight (lb)
T55410-K4	4 pc. of Magnetic Plugs	0.2



Magnet keeps sheet metal in vertical position



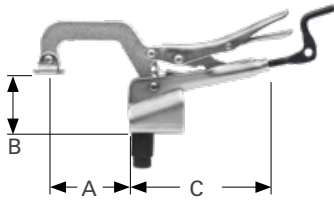

**INSERTA PLIERS**

Insert into Ø5/8" or 16 mm table holes for fast hold-down clamping.

Mount on the Right Angle Bracket, Clamping Squares, or Riser Block for push down clamping at an elevated height for taller workpieces.

The patented crank handle allows clamp pressure adjustment while the clamp is in locked position.

*\* Can be used with Magnetic Top V-Pads. See pg. 39.*



**Fit 5/8" holes**

Part No.	Throat Depth A (in)	Opening B (in)	C (in)	Weight (lb)
PTT522K	2.0	2.3	4.0	0.7
PTT634K	3.4	3.3	5.5	1.2
PTT934K	3.4	4.0	6.5	1.6
PTT956K	5.8	5.5	6.5	1.8

**Fit 16 mm holes**

Part No.	Throat Depth (mm)	Opening B (mm)	C (mm)	Weight (kg)
PT07K	50	60	1.8	0.3
PT09K	100	75	2.5	0.5
PT11K	100	85	2.9	0.7
PT14K	155	120	2.9	0.8



*\*Patent Pending\**

**SWIVEL ADAPTER for Inserta Pliers**

Simply replace the existing stud on the Inserta Pliers with the Swivel Adapter. It allows you to precisely place the tip of the Inserta Pliers anywhere on the table surface.

The Adapter swivels 360° and provides a 1" extension of the Inserta Pliers base for the extended reach, or retraction, of the Inserta Pliers as needed for precise placement of the clamping pad.

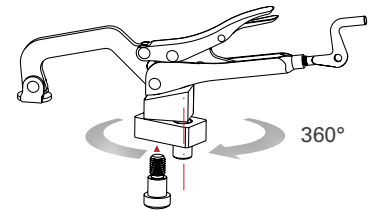

Part No.	Thread	Weight (lb)
T56010	5/16-18	0.4

**REPLACEMENT ADAPTER**

A replacement of the existing stud on the Inserta Pliers.



Part No.	Thread	Weight (lb)
T54620	5/16-18	0.2



# PLIERS

## LOCKING CHAIN PLIERS

Clamp odd shaped multiple items. Hold two workpieces, or a group of materials securely in place while you weld. Adjust tension with crank handle.

- Replaceable chains in different lengths are available.
- Use with optional Table Mount Base Kit on your welding tables.

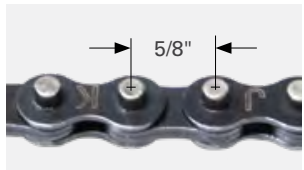

Easy-Remove Screw

Fishtail Chain End

Part No.	Chain Length (in)	Loop Dia. (in)	Weight (lb)
PFC1024	24	up to 6.5	1.9
PFC1036	36	up to 10.5	2.4
PFC1048	48	up to 14	2.8

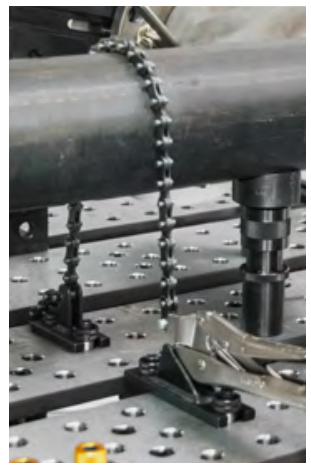

## CHAIN PLIERS MOUNTING BASE KIT

Table-mount chain hook and pliers mounts brackets, USED TOGETHER for table mount part hold down.

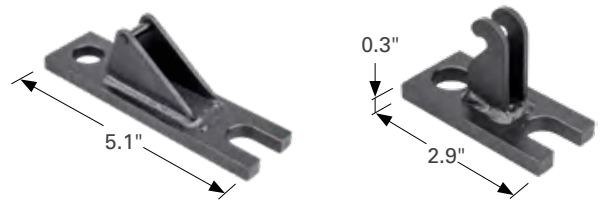

Part No.	Description	Weight (lb)
PXC90	Table Mount Base Kit (2 pc.)	1.1

## REPLACEABLE CHAINS



Part No.	Description	Weight (lb)
PXC24	Replaceable chain 24" L	0.7
PXC36	Replaceable chain 36" L	1.0
PXC48	Replaceable chain 48" L	1.4



**TOGGLE CLAMPS & ADJUSTABLE MOUNTING BASE**

Mount any of the seven Good Hand® Toggle Clamps listed below on this low-profile, pre-tapped Adjustable Mounting Base. Mount Toggle Clamps directly on the BuildPro® Tabletop, Riser Blocks or Econo Stop & Clamping Squares, for the height and reach required for each hold down application.

The thickness of the Aluminum base adds 5/8" to the maximum capacity of the Toggle Clamp.

Use Ball Lock Bolts (not included), to mount the Straight Edge Stop attachment.

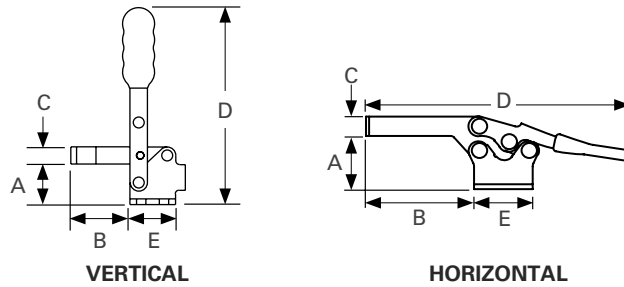

	Part No.	Mounting Hole (in)	A (in)	B (in)	C (in)	D (in)	E (in)	Weight (lb)
Vertical	GH-12050	4 x Ø.20	0.89	1.3	0.38	3.74	1	0.4
	GH-12050-HB	4 x Ø.20	1.66	1.3	0.38	4.80	1	0.4
	GH-12130	4 x Ø.28	1.25	2.8	0.63	5.5	1.4	0.8
	GH-12130-HB	4 x Ø.28	2.25	2.8	0.63	6.5	1.4	0.9
Horizontal	GH-12265	4 x Ø.34	1.75	3.3	0.8	7.5	1.9	1.4
	GH-225-D	4 x Ø.26	1.37	2.8	0.5	6.8	1.5	0.6
	GH-225-DHB	4 x Ø.26	2.13	2.8	0.5	6.6	1.5	0.6

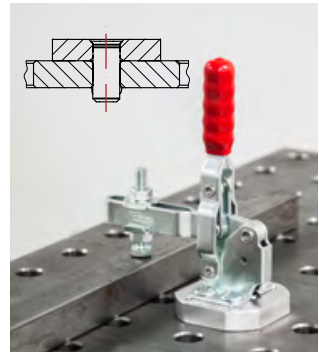

Directly mounted on the table using Flush Mount Ball Lock Bolt.



Mounted with Straight Edge Stop attachment and Ball Lock Bolts.

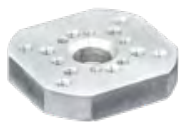
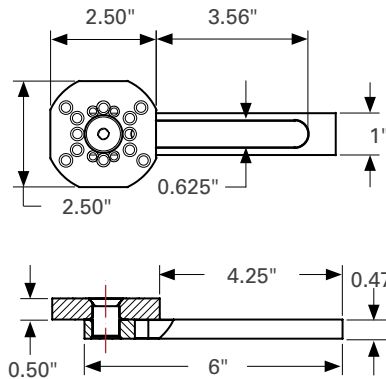
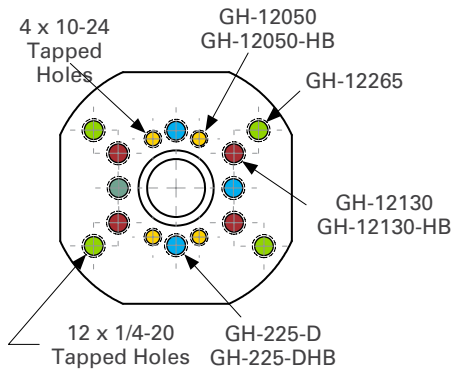

T50505GH-01



T50505GH



Part No.	Description	Weight (lb)
T50505GH-01	Pre-tapped Alum. Base ONLY.	0.3
T50505GH	Includes: pre-tapped Alum. Base + Straight Edge Stop + Flush Mount Screw.	0.7

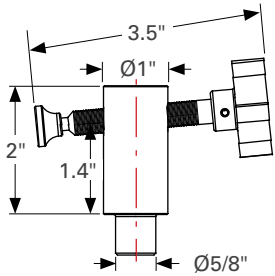

**SIDE CLAMP**

Insert into the Buildpro® table holes for low profile, light duty, horizontal clamping.

A turn of the aluminum knob advances the spindle, bringing the swivel foot to rest against the face of your stock or workpiece.

**Fit 5/8" holes**

Part No.	Stroke (in)	Weight (lb)
TCX5210	1.5	0.6

**Fit 16 mm holes**

Part No.	Stroke (mm)	Weight (kg)
TCX6210	38	0.3



**SIDE PUSH CLAMP XL**

The side push clamp is designed for applying lateral pressure with a slight down force to keep the workpiece from lifting or rolling upwards.

Extra long spindle insures you can reach anywhere on the table. Copper plated spindle resists weld spatter.

A special flipping feature ensures that you can always get the pad placed at the right height, which is useful for smaller material sizes.

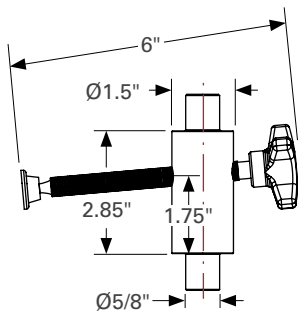

**Fit 5/8" holes**

Part No.	Stroke (in)	Weight (lb)
TCX5320	3.0	2.0

**Fit 16 mm holes**

Part No.	Stroke (mm)	Weight (kg)
TCX6320	76	0.9

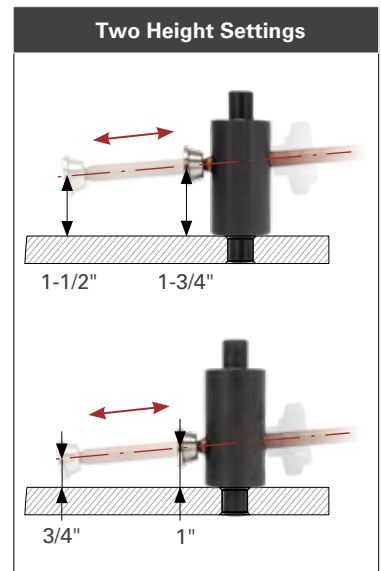

**To change the height of the clamp:**

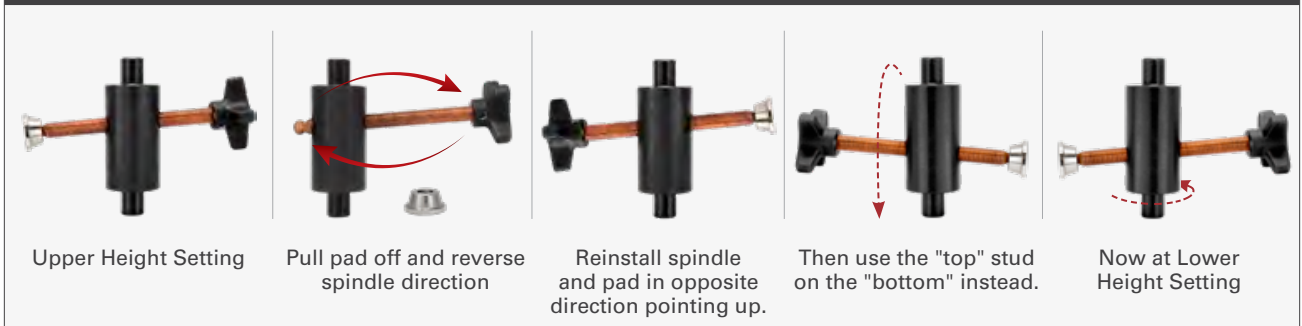

## BALL LOCK BOLTS

### An essential time-saving fastener.

All Ball Lock Bolts are a time-saving and efficient method of locating and fastening fixture elements to the tabletop without having to reach underneath the table.

Insert the Ball Lock Bolt over the fixturing element and turn the knurled head with your hand for initial positioning.

The Ball Lock Bolt consists of three locking steel balls in the bolt shank that move outward to lock against the bottom chamfer of the table plate, pulling the fixture components securely downward and tightening them in place. Once all the Bolts are positioned, tighten the socket head cap screw top of the Bolts with a light turn of a hex wrench. Ball Lock Bolts release quickly from the Bolt top with a turn of your hex wrench.

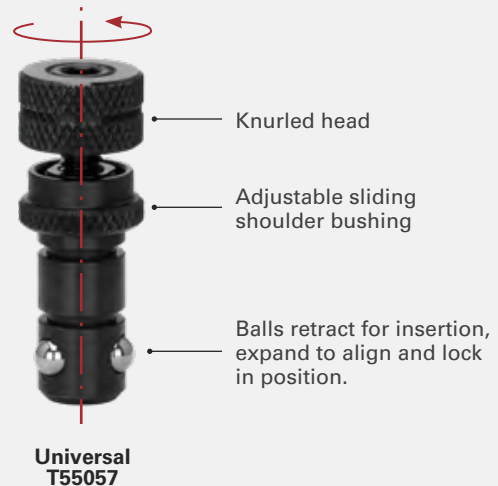

### UNIVERSAL BALL LOCK BOLT

The Universal Ball Lock Bolt features an adjustable sliding shoulder bushing, providing better surface contact while also reducing friction when torquing down screws.



**Adjustable  
T55055**



**Fixed Length  
T55015**



**Fixed Length  
T55010**



**Flush-Mount  
T55020 | T55025**

#### Fit 5/8" holes

Part No.	Type	Description	Capacity (in)	Weight (lb)	Use Hex Wrench	12-pc Bulk Package
T55010	Fixed	For connecting 2 accessories together	0.94	0.2	1/4	T55010-12PPK
T55015		For connecting an accessory to the tabletop	1.1	0.2	1/4	T55015-12PPK
T55020	Flush	For connecting 2 accessories together	0.94	0.1	5/32	-
T55025		For connecting an accessory to the tabletop	1.1	0.1	5/32	-
T55055	Adjustable	Connecting tables to accessories, and accessories to accessories.	0.88 ~ 1.08	0.1	1/4	T55055-12PPK
T55057	Universal	Connecting tables to accessories, and accessories to accessories.	0.88 ~ 1.08	0.2	1/4	T55057-12PPK



**T65030**

#### Fit 16 mm holes

Part No.	Dia (mm)	Description	Capacity (mm)	Weight (kg)	6-pc Bulk Package
T65030	16	Fast Clamping Bolt for clamping 2 components with screw top	4	0.09	BP16-T65030-6PK



# FASTENERS

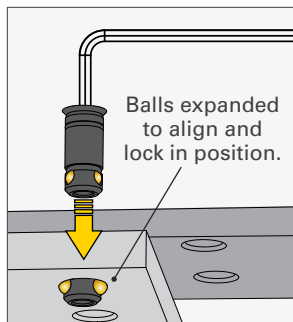

## BALL LOCK BOLT REPLACEMENT

4 Steel Balls and 6 O-Rings



Part No.	Weight (lb)
TMS5101	0.02

## RECEIVER BUSHING

Use the Receiver Bushing with Ball Lock Bolts [Adjustable models and T55015] when mounting two fixturing elements together slot-to-slot.



Part No.	Weight (lb)
T55804	0.03

## LOCATING PIN



T54201

Locating Pins provide an economic alternative to using multiple Ball Lock Bolts.

Use Locating Pins in combination with Ball Lock Bolts to fasten fixturing elements, such as Straight Edge Stops, to the BuildPro Tabletop. Locating Pins aid in holding fixturing elements in position.

*(A minimum of one Ball Lock Bolt must be used along with the Locating Pin to secure accessories to the tabletop. The Locating Pin cannot be used as an independent fastening element.)*



Part No.	Weight (lb)
T54201	0.2

**CONNECTING BOLTS**

These precision shoulder screws fit into the table holes and can hold and position BuildPro® accessories and other components.

Choose from standard and flush-mounted versions. Model T51825-02 is a 2-pc pack for connecting 2 accessories together.



**Standard**  
Hex Wrench: 5/16"



**Flush-Mounted**  
Hex Wrench: 1/4"

(A nut and a washer included.)



**T51825-02**  
Hex Wrench: 1/4"

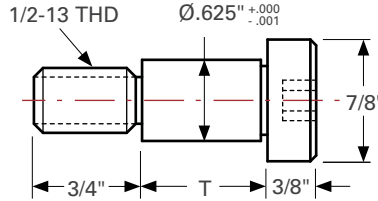

**Standard**

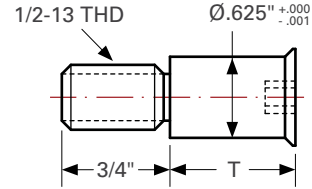

**Flush-Mounted**

Part No.	Type	T (in)	Weight (lb)
T831605	Standard	0.5	0.1
T831607		0.8	0.2
T831608		0.9	0.2
T831610		1.0	0.2
T831612		1.3	0.2
T832607	Flush	0.8	0.1
T832608		0.9	0.1
T832610		1.0	0.1
T832612		1.3	0.2

Part No.	Type	Capacity (in)	Weight (lb)
T51825-02	Flush (Twin Pack)	1.1	0.06

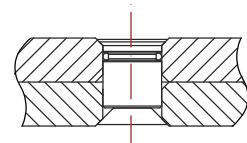
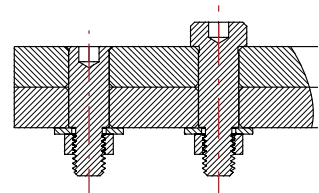

**THREADED ADAPTERS**

Convert any hole in the table into a threaded hole. Place the Adapter in position beneath the tabletop, in alignment with table holes. Magnets hold threaded adapter in place.



**For 2 Threaded Holes with one magnet**

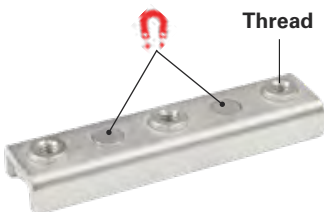

**For 3 Threaded Holes with two magnets**

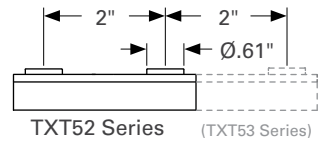

**TXT52 Series (TXT53 Series)**

Part No.	Number of Holes	Threaded Holes	Number of Magnets	Weight (lb)
TXT5203	2	5/16-18	1	0.3
TXT5204		3/8-16		0.3
TXT5205		1/2-13		0.3
TXT5303	3	5/16-18	2	0.6
TXT5304		3/8-16		0.6
TXT5305		1/2-13		0.6

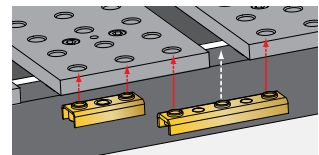

**ECCENTRIC PADS**



T54410

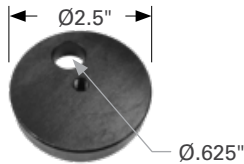

T54415

Using the "CAM" design principle, the eccentric pad provides a quick way to position the edge of the workpiece to a locating stop. The 360° rotation allows infinite adjustments.

Ideal for locating round and odd shape parts where conventional edge stops cannot reach.

\* Eccentric Pads are 1/2" thick.

[Use Ball Lock Bolts, *pg. 44* not included, to mount the Eccentric Pads]

Part No.	Adjust Range (in)	Offset (in)	Thread	Weight (lb)
T54410	0.55 - 0.95	0.2	--	0.2
T54415	0.6 - 2	0.7	5/16-18	0.5

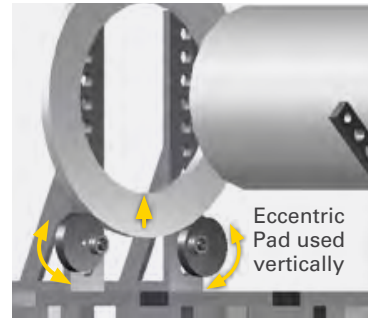

**D-STOP BAR**



The Aluminum D-Stop Bars are lightweight and easy to maneuver. It can be locked into position with Ball Lock Bolts (*pg. 44*), or Socket Head Shoulder Screws (*pg. 46*).

0.47" thicknesses for use as spacers.

Part No.	Dimension (in)	Slot Length (in)	Weight (lb)
T50632-01	4.8 x 1.0 x 0.47	3	0.1





T50505 T50510 T50517

**STRAIGHT EDGE STOPS**

Long slots make these precision machined Straight Edge Stops infinitely adjustable in fixturing applications and squaring up parts.

Use with V-Blocks (*see pg. 55*) for the adjustable fixturing of round tubes.

Part No.	Dimension (in)	Ø.625 Holes	Slot Length (in)	Weight (lb)
T50505	6 x 1.18 x 0.47	1	3.5	0.6
T50510	8 x 1.18 x 0.47	2	2.0	0.8
T50517	10 x 1.18 x 0.47	4	5.0	0.9



**STOPS**

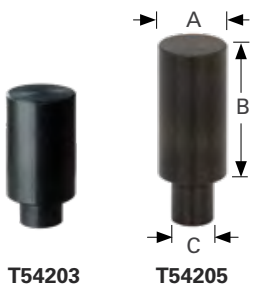

T54203

T54205

T54203 and T54205 are used as a stop wherever parts need to be positively located for clamping.

T64205-4PK is 4-pc pack of stops fit 16 mm holes. They can also be used on Fixturepoint Tabletops.

**Fit 5/8" holes**

Part No.	Ø A (in)	B (in)	Ø C (in)	Weight (lb)
T54203	1.0	1.5	0.625	0.4
T54205	1.0	2.0	0.625	0.5

**Fit 16 mm holes**

Part No.	Ø A (mm)	B (mm)	Ø C (mm)	Weight (kg)
T64205-4PK	25	50	16	0.4





## CLAMPING SQUARES

### RIGHT ANGLE BRACKETS

These precision machined angle squares hold material at 90°. The holes and slots combination allow for infinite adjustments in fixturing. For heavy duty applications, see the Riser Blocks on *pg. 50*.



Part No.	Dimension (in)	Plate Thickness (in)	Holes	Slot Length (in)	Weight (lb)
T50304	1.6 x 3.6 x 1.18	0.47	1	2.6	0.5
T50305	3.6 x 3.6 x 1.18		3	2.6	0.7
T50310	3.6 x 6 x 1.18		3	5.0	1.0
T50330	12 x 6 x 2		11	5.0	4.5

### ECONO STOP & CLAMPING SQUARES \*

Economy Stop and Clamping Squares feature three surfaces for use in a wide variety of fit up applications.

Place Inserta Pliers or Inserta Clamps into any of the CNC machined holes for horizontal or vertical clamping at any height. Stack the Clamping Squares to brace tall workpieces. Use the top holes for mounting the Squares in a fixed location. The lower base is slotted for adjustable mounting.

Top and bottom plates are 0.47" thick and front sides are 0.12" thick.



Part No.	Dimension (in)	Weight (lb)
T50205	2 x 4.5 x 4	2.3
T50210	2 x 5.5 x 8	3.1
T50215	2 x 5.5 x 12	4.2

\* The Econo Stop & Clamping Squares will be discontinued by the end of 2021 and only available while stock lasts.



**MALLEABLE IRON CLAMPING SQUARES**

Versatile four-sided Clamping Squares. CNC machined faces.

T50231 & T50230 have 26 Holes, 2 Slots on each.

T50251 & T50250 have 43 Holes, 7 Slots on each.



T50231

T50230



T50251

T50250

Part No.	Description	Dimension (in)	Weight (lb)
T50231	Left Angle	2 x 6 x 12	6.4
T50230	Right Angle	2 x 6 x 12	6.4
T50251	Left Angle	2 x 8 x 20	14.8
T50250	Right Angle	2 x 8 x 20	14.8



**HEAVY DUTY RISER BLOCKS**

**Slotted end for adjustable mounting.**

These nitrided five-face precision machined Riser Blocks feature accurate bored holes in a diagonal pattern.

Use Riser Blocks individually, or stacked, to elevate a workpiece or clamp. Cross join the Blocks for use as a beam. Use the Blocks to mount a BuildPro® plate to the side or end of the table, or to join tables together.

Models T50120, T50125, and T50130 feature two slots at one end for adjustable positioning.



T50115

T50120

T50125

T50130

Part No.	Machined Surfaces	Dimension (in)	Weight (lb)
T50115	4 faces	2 x 2 x 10	4.4
T50120	5 faces	4 x 4 x 4	7.5
T50125		4 x 4 x 8	12.6
T50130		4 x 4 x 12	17.4

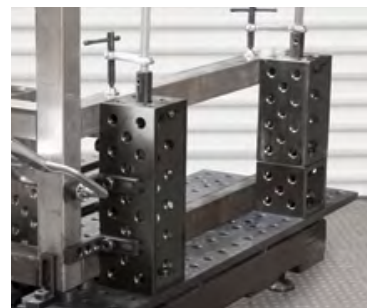

## CLAMPING SQUARES



T50141



T50143

**HEAVY DUTY RISER BLOCKS**

Six slots for adjustable mounting.

Heavy Duty Blocks are ideally suited for large vertical setups or joining multiple tables together for long projects.

Both Heavy Duty Riser Blocks are nitrieded and have total of 6 slots on the top, bottom, and side surface.

Available in 24" long and 36" long. T50141 has 157 Holes. T50143 has 235 holes.

Part No.	Dimension (in)	Weight (lb)
T50141	8 x 4 x 24	53
T50143	8 x 4 x 36	77

**ADJUSTABLE ANGLE BLOCK**

Made of cast iron, this adjustable angle block features a radiused corner and quarter circle slot that allows you to adjust and lock in angles anywhere between 0 to 90 degrees by using two Ball Lock Bolts.

Adjustable Angle Block has four straight slots, one quarter circle slot and six 5/8" boreholes.

Part No.	Dimension (in)	Weight (lb)
T50121	4.1 x 3.7 x 3.7	4.7







T51825

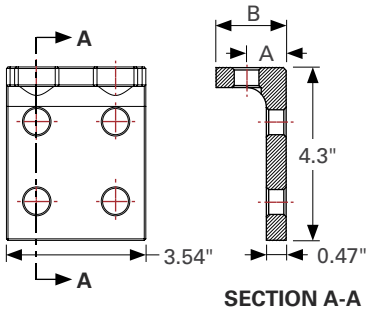

## SIDE BRACKETS

Locate or clamp your weldment at or beyond the table edge, by mounting the Side Bracket at the edge of your slotted and MAX Tabletop.

Use the Side Bracket to vertically mount clamping elements, such as the Straight Edge Stops or Right Angle Brackets to add greater functionality to your table in fixturing oversized weldments.

Part No.	A (in)	B (in)	Mounting Location	Weight (lb)
T51825	1.010	1.475	MAX Tables - END or SIDE Slotted Tables - END Rhino Cart - ANY SIDE	2.5
T51830	1.181	1.700	Slotted Tables - SIDE	2.5

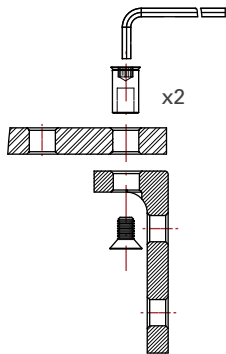

Slotted table shown

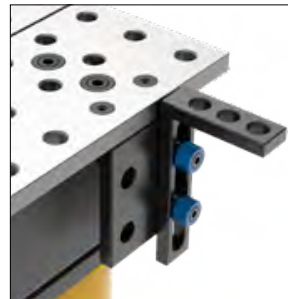

MAX table shown



T51825 on any side of Rhino Cart



T51006



T51009



T52005-01

## FIXTURING PLATES

The versatile plate can be used as a fixturing element, or as a link to connect two tables together.

Part No.	Finish	Description	Thickness (in)	Weight (lb)
T51006	Nitrided	4" x 6.3" Fixturing Plate, 6 holes	5/8	4.2
T51009	Nitrided	6" x 6.3" Fixturing Plate, 9 holes	5/8	6.3
T52005-01	Nitrided	20" x 6.3" Fixturing Plate	5/8	20





## ADJUSTABLE & FIXED RESTS

Developed by customer demand, the Adjustable Rests are operated manually, by hand adjustment, with a turn of the easy-grip knurled band for complete control in precise, minute height adjustment. (PN T54213: Range: 2"~2-3/4". PN T54212: 7/8" height with 5/16" stroke range.)

Insert into any fixturing hole on the BuildPro® Modular Welding Table for use as a support or rest for aligning stock at a uniform height and providing welding clearance.

The rests feature 5/8" bored hole on top to hold V-Blocks and V-Block Spacers. They fit into the top cavity of the rests to support round pipes. Rests are stackable for use with tall stock.

**Both T54213 and 214 have two interchangeable Locating Posts.**

### Three mounting options:

- Insert into any hole on the BuildPro table with the Ø5/8" Locating Post.
- Securely fasten to the tabletop for repetitive applications using the Locking Pin with cap screw (included).
- Remove the Locating Post or the Locking Pin, and place the Rest anywhere on the BuildPro tabletop.

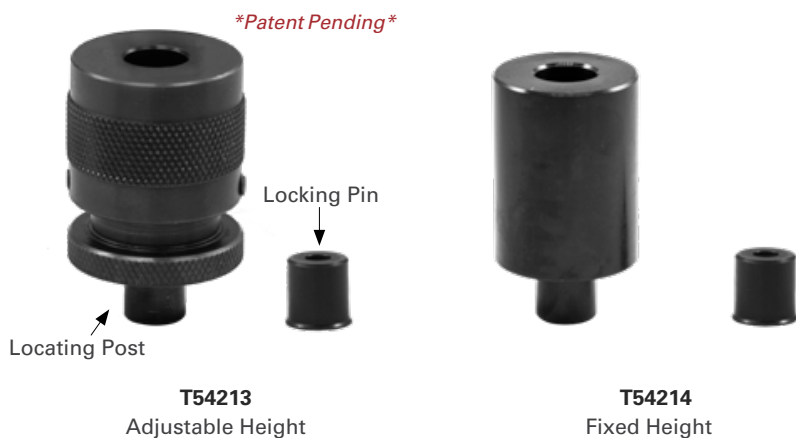

After setting at the desired height, tighten set screw to LOCK.

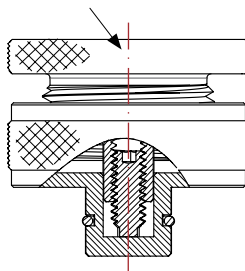

Part No.	Top Dia. (in)	Locating Post Dia. (in)	Height (in)	Weight (lb)
T54213	1.75	5/8	2.0 ~ 2.8	1.1
T54212	1.75	5/8	7/8 ~ 1-3/16	0.5
T54214	1.5	5/8	2.0	0.7

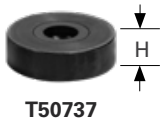

## MAGNETIC REST BUTTONS

Magnets on the bottom of the Magnetic Rest Buttons allow the button to be used at ANY point on the tabletop to elevate workpieces.

Stack Magnetic Rest Buttons to elevate workpieces in 0.45", 0.625", and 1" increments.

Part No.	Dimension Ø x H (in)	Weight (lb)
T50737	1.5 x 0.45	0.2
T51740	1.5 x 0.625	0.4
T51745	1.5 x 1.0	0.6

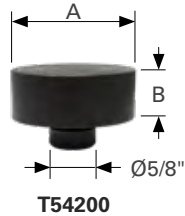
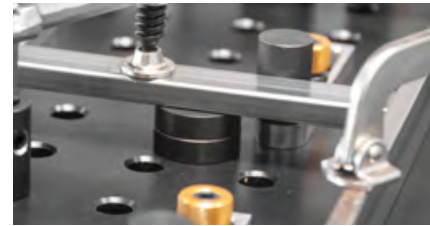

## REST BUTTONS

The rest button serves as a part rest to elevate parts above the table top.

Part No.	Ø A (in)	B (in)	Weight (lb)
T54200	1.6	0.6	0.4
T54206	1.0	1.0	0.1
T54208	2.0	1.0	0.4



## SHIM SUPPORTS 24-PC SET

A 24-piece Set of Shims offers the option to create height-adjustable work surfaces.

The individual Shim can be utilized to compensate for height differences of 0.0625"~0.25". In order to achieve the intended height precisely, the lowest grading of the Shim is 0.0625". The measurements are specified on the particular discs.



Part No.	Description	Inner Dia. (in)	Outer Dia. (in)	Weight (lb)
T55300-24PK	Set of Support Shim 24 pieces - 8x Ø 0.0625" thickness 8x Ø 0.125" thickness 8x Ø 0.250" thickness"	0.65	1	0.45

## RESTS



### HEAVY DUTY V-BLOCKS

Developed by customer demand, these Heavy Duty V-Blocks hold round stock from 3" – 8" in diameter at 120° - 150°.

Part No.	Angle	Dimension (in)	Max. Tube Size (in)	Weight (lb)
T54310	120°	Ø2.4 x 1.7	3"	1.2
T54315	150°	Ø3.2 x 1.4	8"	1.5

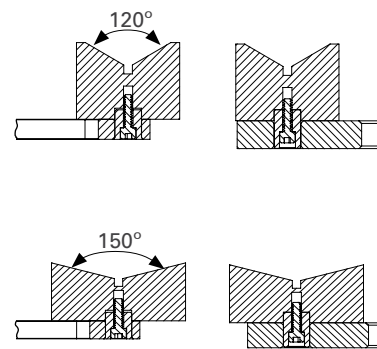

### V-BLOCKS

V-Blocks are designed to hold round parts. They fit into the holes of the: BuildPro® Table, Riser Blocks and Right Angle Brackets.

Part No.	Angle	Dimension (in)	Max. Tube Size (in)	Weight (lb)
T54210	90°	Ø1.6 x 1.3	2.0	0.3
T54215	120°	Ø1.6 x 1.1	2.5	0.3
T54216	120°	Ø1.6 x 0.9	2.5	0.1

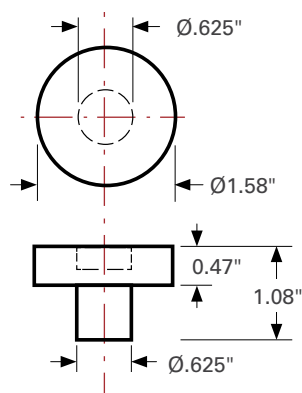

### V-BLOCK SPACER

Use the V-Block Spacer T54211 to elevate V-Blocks 0.47" for height uniformity when fixturing with the Straight Edge Stops.



Part No.	Weight (lb)
T54211	0.2



## BEND RESTS

The Bend Rest supports round stock at bends and elbows in fixturing, preventing lateral movement and providing clamp support.

The low profile design allows use of multiple Bend Rests as needed to elevate stock, leaving ample space for clamping.

Place Bend Rests directly into any hole on the BuildPro® Tabletop, or use in combination with BuildPro® Rests to set at desired height to meet clearance or alignment requirements for each unique fixture.

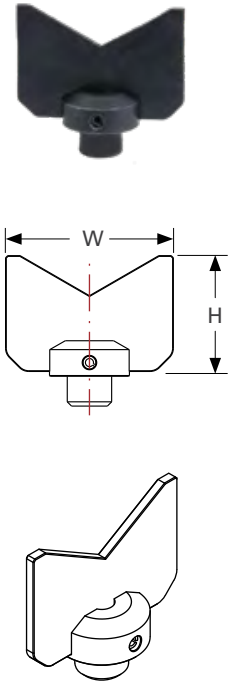

Part No.	Angle	W x H (in)	Max. Tube Size (in)	Weight (lb)
T54320	120°	2.4 x 1.2	2.5	0.3
T54325	120°	2.4 x 1.7	3.0	0.3
T54330	150°	3.2 x 1.3	8.0	0.3

## SETUP CONE

Use the Setup Cone to locate and position round tubing horizontally or vertically through the centerline. The Setup Cone locates from within the tube ID [max. 1-1/2"] at the tube ends, allowing for centerline location and positioning. Mount the Setup Cones on BuildPro® Accessories using either of two interchangeable bases provided:



**Horizontal clamping:** Securely fasten to any 5/8" mounting hole on clamping accessories using the Locking Pin with cap screw.

**Vertical clamping:** Insert into any 5/8" mounting hole on clamping accessories or the tabletop, using the Locating Post.

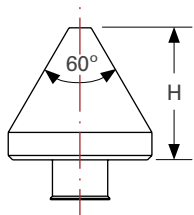

Horizontal application using Locking Pin



Vertical application using Locating Post + V-Block Spacer

Part No.	Angle	Dia. x H (in)	ID Pipe Range (in)	Weight (lb)
T54220	60°	1.625 x 1.5	.25 < x < 1.625	0.5



## RESTS

### SLOT FILLER KIT \*

Use the Channel Block and Rest Button when a flat, continuous support surface is required directly over the 1.7" table slots.

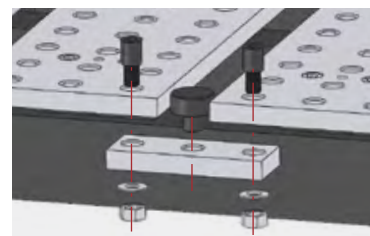
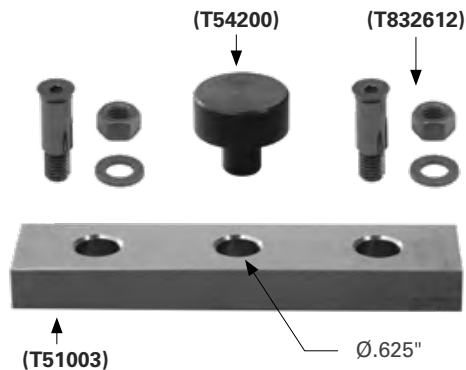

Mount the Channel Block and insert the Rest Button to create a continuous work surface over the table slot.

Part No.	Includes	Weight (lb)
T50930	1 pc. Channel Block (T51003) 6.3" x 1.6" x 0.63" 1 pc. Rest Button (T54200) 2 pc. Flush-mounted Screws (T832612)	2.4

\* Not applicable to slotless tables.

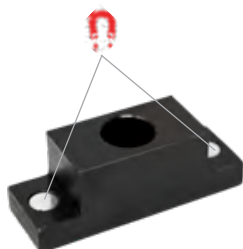

**T50940**  
One Ø5/8 hole

### T-SLOT ADAPTERS \*

Slide the T-Slot Adapter into any table slot to create a Ø5/8 table hole along the table slots as needed in fixturing. (Tapped hole is consistent with table hole depth and diameter.)

Locate and mount any fixturing element [Right Angle Brackets, Riser Blocks, Econo Stop & Clamping Squares] directly over table slots.



**T50950**  
Two Ø5/8 holes

Part No.	Weight (lb)
T50940	0.4
T50950	1.3

\* Not applicable to slotless tables.



**T51300**



**T51305**

### SLIDING CHANNEL BASES \*

Mount work-holding devices onto these Sliding Channel Bases. Slide into the 1.7" slots between the plates.

Part No.	Description	Weight (lb)
T51300	Non-rotatable and without holes for user customization.	1.5
T51305	Rotatable with 1/2-13 threaded hole on one side, 3/8-16 on the other side.	1.4

\* Not applicable to slotless tables.

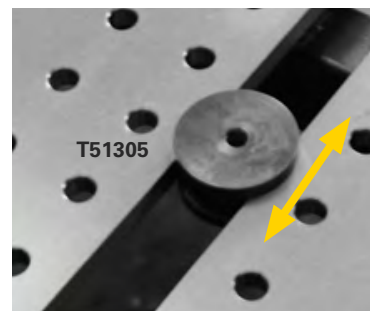

# UNIVERSAL FLANGE CLAMPING PLATE



**Hold ASME / ANSI / DIN Standard Flanges in position for flange + pipe joining!**

**Reduce set-up time and increase weld quality for greater repeatability.**

Hold, accurately locate, and securely clamp down standard flanges. Guide Blocks in the Flange Clamping Plate expand or contract symmetrically to accurately locate the flange for greater weld quality. The patented Flange Clamping Plate provides full welding clearance, and allows easy removal of the finished weldment.

Fits standard flanges with these specifications:

- Hole circle diameter range: 3" ~ 18.3"
- Number of bolt holes: 4, 8, 12, 16

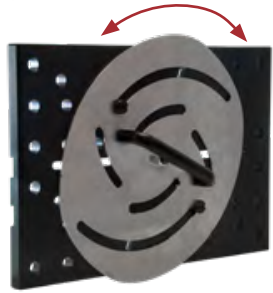

Inserta Pliers



Locating Pins

Part No.	Kit Includes	Dimension (in)	Weight (lb)
T50430	1 pc. Universal Flange & Pipe Clamping Plate w/ 8 Locating Pins: 2 of each size - 1", 7/8", 3/4", 5/8"; 2 pc. Part No. PTT634KF Inserta Pliers.	18 x 12 x 3/4	42.7



The fixture is strong and rigid, to withstand cumulative stresses resulting from welding, and holds the joined flange & pipe during cool down to prevent distortion, expansion, and contraction.

Load the flange & pipe, accurately position, and unload quickly for quality welds, maximum productivity, and repeatability.

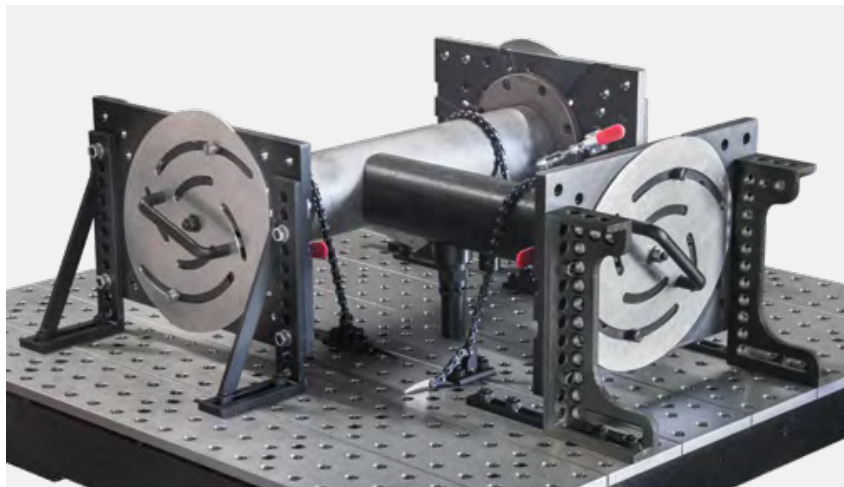

Use multiple Universal Flange & Pipe Fixtures to setup pipes for a T-Joint.

Find the fixturing video on:  
[youtu.be/dww1Xj1KfHc](https://youtu.be/dww1Xj1KfHc)



**FORGED VISE**

This forged steel 4" Bench Vise features a 360° swivel base, large machined anvil surface, powder coated finish. Made of 90,000 PSI tensile strength forged steel. Swivel base is patterned to bolt directly to table.

Rear jaw of the vise hangs over the edge of the table when mounted on edge. Vise can also be mounted with Ball Lock Bolts for quick mounting and dismounting.



Four Socket Shoulder Screws (Part No. T831610) included.

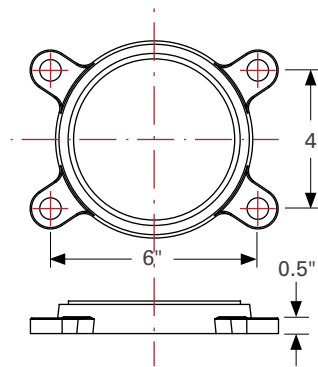

Part No.	Jaw Width (in)	Jaw Opening (in)	Pipe Capacity (in)	Throat Depth (in)	Clamping Force (lb)	Handle Dia. (in)	Handle Length (in)	Max Torque (ft/lb)	Weight (lb)
TXV5-4-K	4	5	0.5 ~ 2	2.9	5,000	0.435	7.125	118	22

**TOOL CART**

“Fully Open” design for visibility and quick access.

The BuildPro® Tool Cart will help you inventory and organize your BuildPro Clamps and Components, and keep them within arm’s reach for faster fixture setup, and tear down.



Dedicated placement for each clamp and component makes the cart easy to setup and maintain. Smart design features allow for quick, convenient "park and pickup" of the Clamps and Components.

The Cart is constructed from 2" x 1" tubing with a rust resistant powder coated black finish. Two fixed casters and two swiveling casters with foot pedal safety lock provide easy maneuverability.



Use the Cart to hold any of the BuildPro Fixturing Kits. (Kits sold separately.)

Part No.	Description	Dimension W x D x H (in)	Capacity (lb)	Gross Weight (lb)
TMC8080-K1	Tool Cart with 8 Storage Bins (4x sm, 4x lg)	31 x 20 x 43	220	92
TMC8080	Tool Cart Only	31 x 20 x 43	220	88
TMC8080-01-4PK	Storage Bins, 4-pc Pack, Sm.	6.5 x 4 x 3	-	1.0
TMC8080-02-4PK	Storage Bins, 4-pc Pack, Lg.	9 x 6 x 5	-	2.4



# NOTCHER

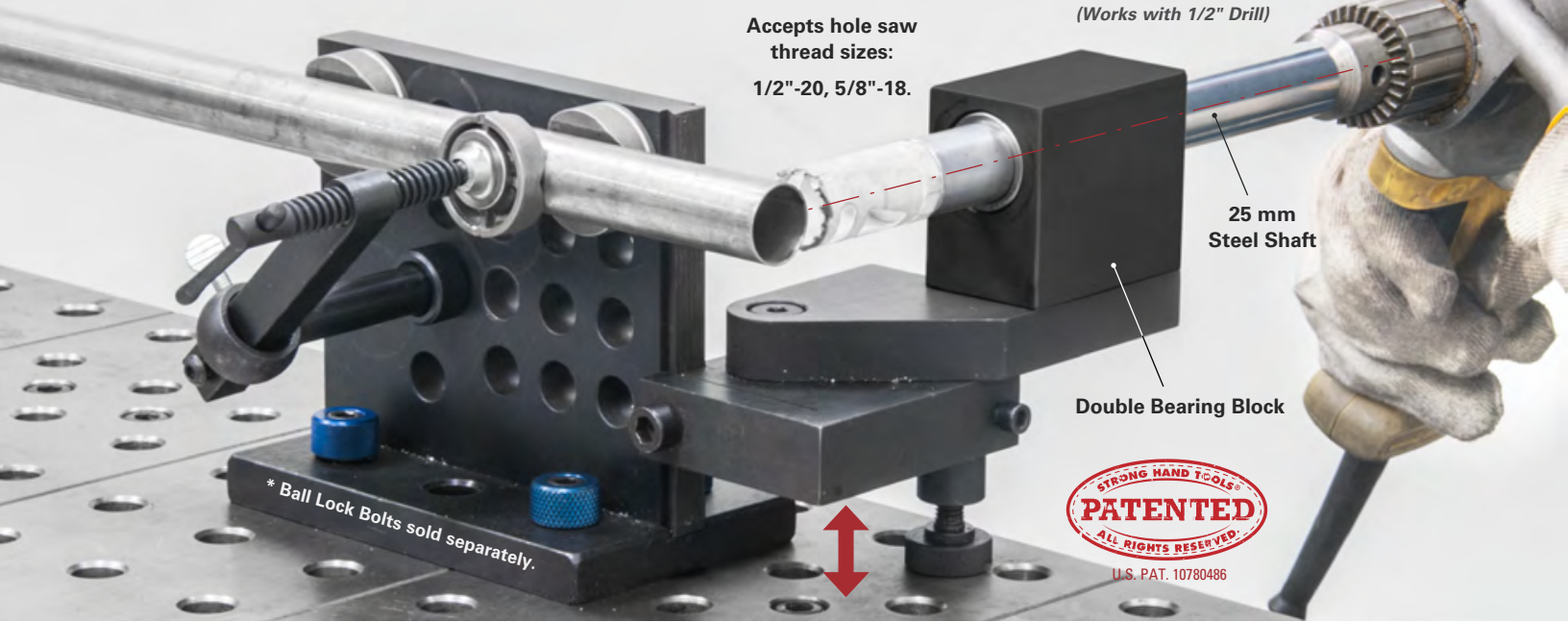

Accepts hole saw thread sizes:  
1/2"-20, 5/8"-18.

(Works with 1/2" Drill)

25 mm Steel Shaft

Double Bearing Block



BuildPro® Tube & Pipe Notcher  
(1 pc.)

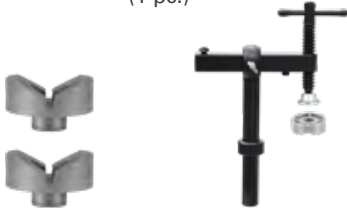

Aluminum V-Blocks  
(2 pcs.)

Clamp with Magnetic V-Pad  
(1 pc.)

## Notch tubes and pipes at the accurate angle and length.

Mounting your Notcher on the BuildPro® welding tables, Fixturing Plates or mobile working stations allows for quick and accurate setups when notching multiple parts.

Notch 1" ~ 2-1/2" OD pipes or square tubes at any angle, or off-center. Position the two V-Blocks and clamp as needed.

Part No.	Kit Includes	Weight (lb)
ATN100	1 pc. BuildPro® Tube & Pipe Notcher 2 pcs. Aluminum V-Blocks for tube locating 1 pc. Clamp with Magnetic V-Pad	20



Height Setting Scale

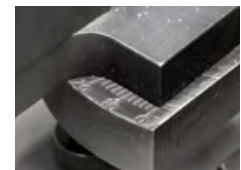

Angle Setting Scale

Arrange the Clamp and Aluminum V-Blocks on the Modular Fixturing Block as needed for proper part positioning in each notching application.



# NOTCHER

In the examples below, the BuildPro® Tube & Pipe Notcher is used to notch workpieces as needed to fit seamlessly into a final assembly:

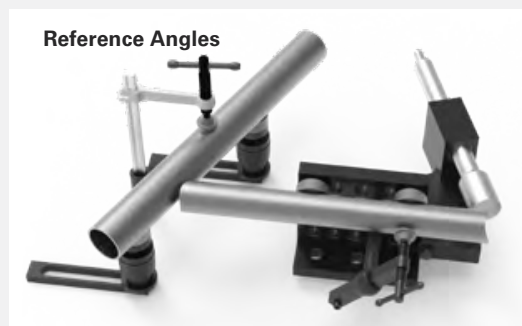
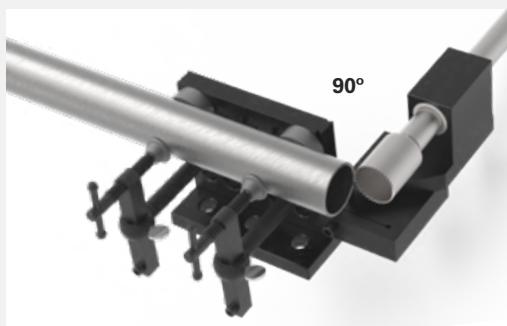
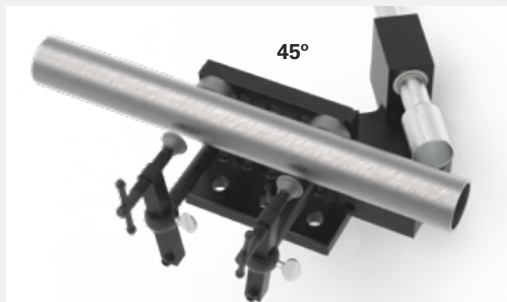

## ADDITIONAL ACCESSORIES FOR NOTCHER:



### NOTCHER ADAPTER

The Adapter is compatible with: Annular cutter with 3/4" shank.

\* Annular cutter not included.

Part No.	Weight (lb)
ATNA20	0.2



### CLAMP KIT FOR NOTCHER

T-Post Clamp with Magnetic V-Pad for use with notcher.

Part No.	Weight (lb)
ATNC50	1.5



### ALUMINUM V-BLOCKS

Aluminum V-Blocks for tube positioning. See pg. 55 for details.

Part No.	Weight (lb)
T54216	0.05

**SURGE PROTECTOR POWER STRIPS**

**Individual Switches, Wall Mountable Surge Protector with 5 Outlets & 2 USB Ports**

- Heavy duty aluminum housing is strong, durable, high temperature and impact resistance.
- 5 outlets and 2 USB ports with individual switches make it flexible to turn off the equipment independently. Safer and more energy-saving.
- The "Main" switch can power off all the equipment at one click.
- 1200 joules suppression rating protects from power surges and spikes.
- 6 ft and 10 ft long extension cord options.
- Includes two mounting holes on the back.

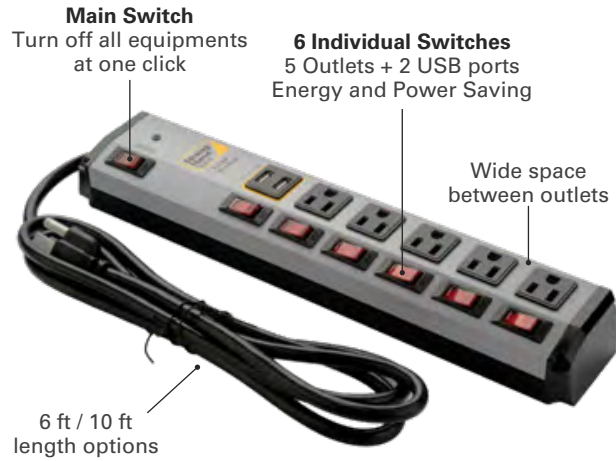

**Electrical Rating:** 1875W, 15A, 125VAC, 60Hz

**USB Output:** 5VDC, 2.4A Total

**Surge Protect Capacity:** 1200J

Part No.	Dimension W x D x H (in)	Cord Length (ft)	Weight (lb)
EPS526	14 x 2.6 x 1.7	6	2.2
EPS529	14 x 2.6 x 1.7	10	3.3

**TABLE GROUNDING ADAPTOR**

This grounding clamp offers an excellent solution for grounding to 5/8 fixturing tables for welding applications. The connectors are designed to easily twist-lock on and off while delivering consistent ground. The clamp is designed to fit into any standard 5/8" or 16 mm diameter hole of 1/2" depth or greater.

Grounding capacity will vary based on the cable used, but is designed to fit up to 3/0 size cables.

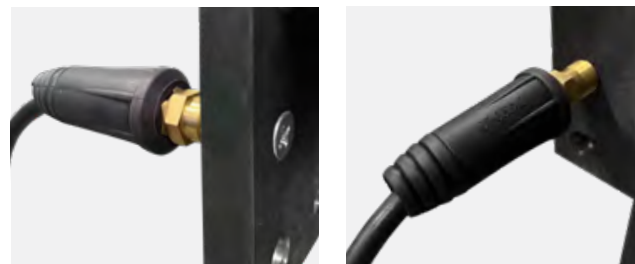
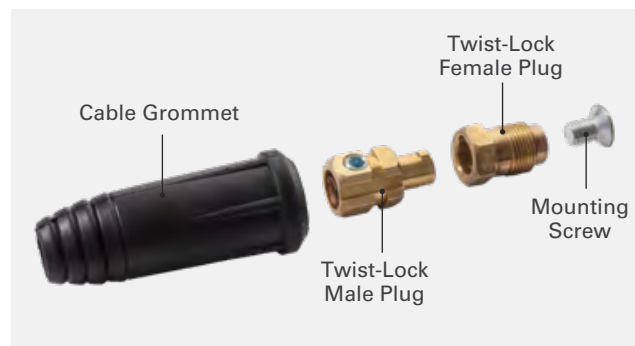

Part No.	Dimension (in)	Weight (lb)
T54700	6 x 1.5	0.4

## SPECIAL TOOLS

### CLEANING BRUSH

This nylon brush with protecting handle is designed for cleaning 16 mm and 5/8" fixturing holes in BuildPro welding tables, blocks and squares.

The brush can be attached to your own power drill for fast cleaning.

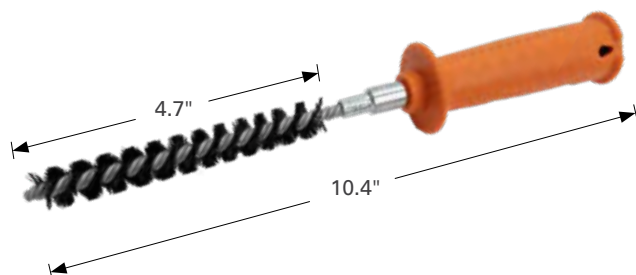

Part No.	Weight (lb)
T58820	0.3

### BENCH STONE

Ideal for removing damages or fine welding spatters and maintaining the smooth surface of the welding table.

- Large stone is made of top-grade silicon carbide.
- 100 grit on top and 400 grit at the bottom can be used for standard table surfaces.
- Non-slip rubber at the bottom.



Part No.	Stone Dimension (in)	Overall Dimension (in)	Weight (lb)
T58940	6 x 2 x 1	7.4 x 2.2 x 1.5	0.9

### WELD-AWAY SPATTER SPRAY

Not only does it effectively remove weld spatter, but it also eliminates mill and process oils with ease. A simple wipe with a damp cloth is all that's needed to prepare most surfaces for painting.

Formulated with non-chlorinated solvents, silicones, and hydrocarbons, Weld-Away is completely non-flammable and non-toxic.

Suitable for all welding area surfaces, including walls, machines, robots, fixtures, curtains, and screens. Just spray and wipe for a sparkling clean surface.

Part No.	Size	Weight (lb)
T58724	24 fl oz	1.7
T58728	1 gal	8.7





## FIXTUREPOINT JIG & FIXTURETABLE

### A Light Weight, Compact Modular Fixturing System.

The economy priced FixturePoint Table is ideal for the setup of 2D frames and other basic fixtures.

Choose from two fixturing kits that mate to the 16 mm holes on the 36" x 24" x 0.16" tabletop.

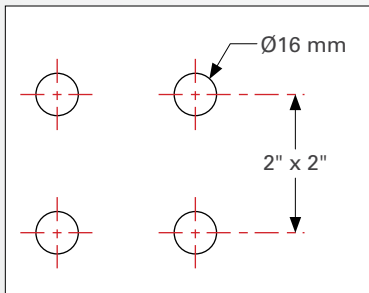

The FixturePoint™ tabletop can be detached from the leg frame for placement on alternate work surfaces as needed.



Check our website: [buildprotables.com](http://buildprotables.com) for more details about FixturePoint system.





## PORTABLE FIXTUREPOINT WELDING TABLE

**Portable, positionable welding table for TIG welding of small parts.**

Rigid construction, multi-angle settings. Easily moves around the shop!

Create your setup in the horizontal position, then set the ideal tabletop angle for worker comfort in each unique project! Parts stay securely clamped in position at any angle.

<b>Tabletop Size:</b>	24" x 18"
<b>Top Plate Thickness:</b>	4 mm
<b>Hole Diameter:</b>	16 mm
<b>Grid Pattern:</b>	2" x 2"
<b>Loading Capacity:</b>	60 lb

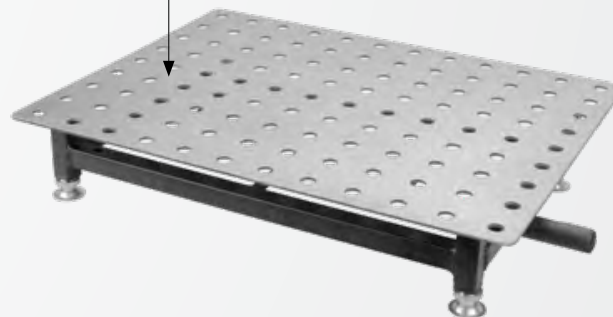
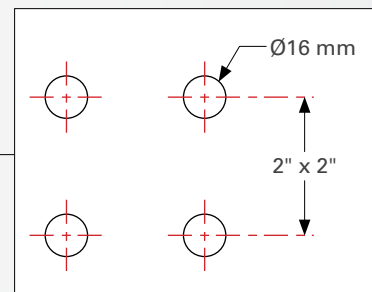

Adjust tabletop angle for worker comfort in each unique project!



Rigid construction, multi-angle settings: 30°, 45°, and 65°.



Leveling Pad adjust from 0 ~ 1.6"

**Check our website:**  
[buildprotables.com](http://buildprotables.com)  
**for Portable  
 FixturePoint Table  
 with 12-pc Clamping  
 Kit "TB52418-K1".**

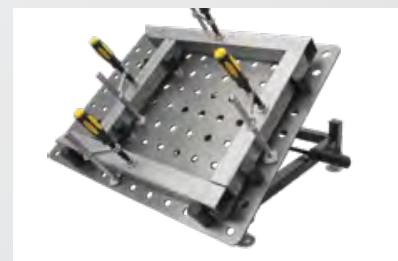

## PART NO. TMK810

34-pc. BuildPro Fixturing Kit | Gross Weight: 30 lb



UDN5150	PTT634K	PTT934K	T54205	T55057
4x	2x	2x	4x	12x



T50505	T50305	T50310	T50330
4x	2x	2x	2x

## PART NO. TMK820

78-pc. BuildPro Fixturing Kit | Gross Weight: 53 lb



UDN5150	UEN5200	TCX5210	PTT634K	PTT934K	T50505
4x	4x	2x	2x	2x	4x



T50304	T50305	T50310	T50330	T55057	T54201
2x	2x	4x	2x	24x	2x



T54205	T54216	T54211	T50737
4x	8x	4x	8x

# MODULAR FIXTURING KITS

**PART NO. TMK830**

**97-pc. BuildPro Fixturing Kit | Gross Weight: 179 lb**

				
UDN5150	UEN5200	T51670	TCX5210	PTT634K
4x	4x	2x	2x	2x
				
PTT934K	T55057	T54201	T54205	T50505
2x	36x	2x	4x	4x
				
T50304	T50305	T50310	T50330	T50231 + T50230
2x	2x	4x	2x	2x + 2x
				
T54216	T54211	T50737	TMC8080	
8x	4x	8x	1x	

TABLES & ACCESSORIES

MOBILE WORKING STATIONS

PLATFORMS

FIXTURE ELEMENTS

SPECIAL TOOLS

KITS

**PART NO. TMK840** 127-pc. BuildPro Fixturing Kit | Gross Weight: 225 lb



<b>UDN5150</b>	<b>UEN5200</b>	<b>UERN5200</b>	<b>T51670</b>	<b>TCX5210</b>
4x	8x	2x	4x	4x



<b>PTT634K</b>	<b>PTT934K</b>	<b>PTT956K</b>	<b>PFC1048 + PXC90</b>	<b>T55057</b>
2x	4x	2x	2x + 2x	36x



<b>T54201</b>	<b>T54205</b>	<b>T50505</b>	<b>T50304</b>	<b>T50305</b>
2x	4x	8x	4x	4x



<b>T50310</b>	<b>T50330</b>	<b>T50231 + T50230</b>	<b>T54216</b>	<b>T54211</b>
8x	2x	2x + 2x	8x	4x





















<b>T50737</b>	<b>TMC8080</b>
8x	1x



# MODULAR FIXTURING KITS

**PART NO. TMK850**

**149-pc. BuildPro Fixturing Kit | Gross Weight: 314 lb**

				
<b>UDN5150</b>	<b>UEN5200</b>	<b>UERN5200</b>	<b>T51670</b>	<b>TCX5210</b>
4x	8x	2x	4x	4x
				
<b>PTT634K</b>	<b>PTT934K</b>	<b>PTT956K</b>	<b>PFC1048 + PXC90</b>	<b>T55057</b>
2x	4x	2x	2x + 2x	48x
				
<b>T54201</b>	<b>T54205</b>	<b>T50505</b>	<b>T50304</b>	<b>T50305</b>
4x	4x	8x	4x	4x
				
<b>T50310</b>	<b>T50330</b>	<b>T50231 + T50230</b>	<b>T50120</b>	<b>T50125</b>
8x	4x	2x + 2x	2x	2x
				
<b>T50130</b>	<b>T54216</b>	<b>T54211</b>	<b>T50737</b>	<b>TMC8080</b>
2x	8x	4x	8x	1x

TABLES & ACCESSORIES

MOBILE WORKING STATIONS

PLATFORMS

FIXTURE ELEMENTS

SPECIAL TOOLS

KITS

## PART NO. TU52020-K1

Manipulator with 30-pc. Fixturing Kit | Gross Weight: 240.3 lb



TU52020

1x



UDN5150

2x



PTT634K

2x



T55057

6x



T54205

4x



T50304

2x



T50305

2x



T54216

4x



T50737

8x

## PART NO. TUK5300

30-pc. Fixturing Kit Only | Gross Weight: 13.2 lb



UDN5150

2x



PTT634K

2x



T55057

6x



T54205

4x



T50304

2x



T50305

2x



T54216

4x



T50737

8x

# RHINO CART FIXTURING KITS

**PART NO. TD5-4830Q-K1**

**Rhino Cart with 66-pc. Fixturing Kit | Gross Weight: 515 lb**



TD5-4830Q-F1	UDN5150	PTT522K	PTT634K	TCX5210	T54217
1x	2x	2x	2x	2x	2x



T50632-01	T50304	T50305	T55057	T54201	T54203
8x	2x	2x	10x	2x	4x



T54205	T50737	T54216	T54211
4x	12x	8x	4x



**PART NO. TDK5100**

**66-pc. Fixturing Kit Only | Gross Weight: 20.3 lb**



UDN5150	PTT522K	PTT634K	TCX5210	T54217
2x	2x	2x	2x	2x



T50632-01	T50304	T50305	T55057	T54201
8x	2x	2x	10x	2x



T54203	T54205	T50737	T54216	T54211
4x	4x	12x	8x	4x



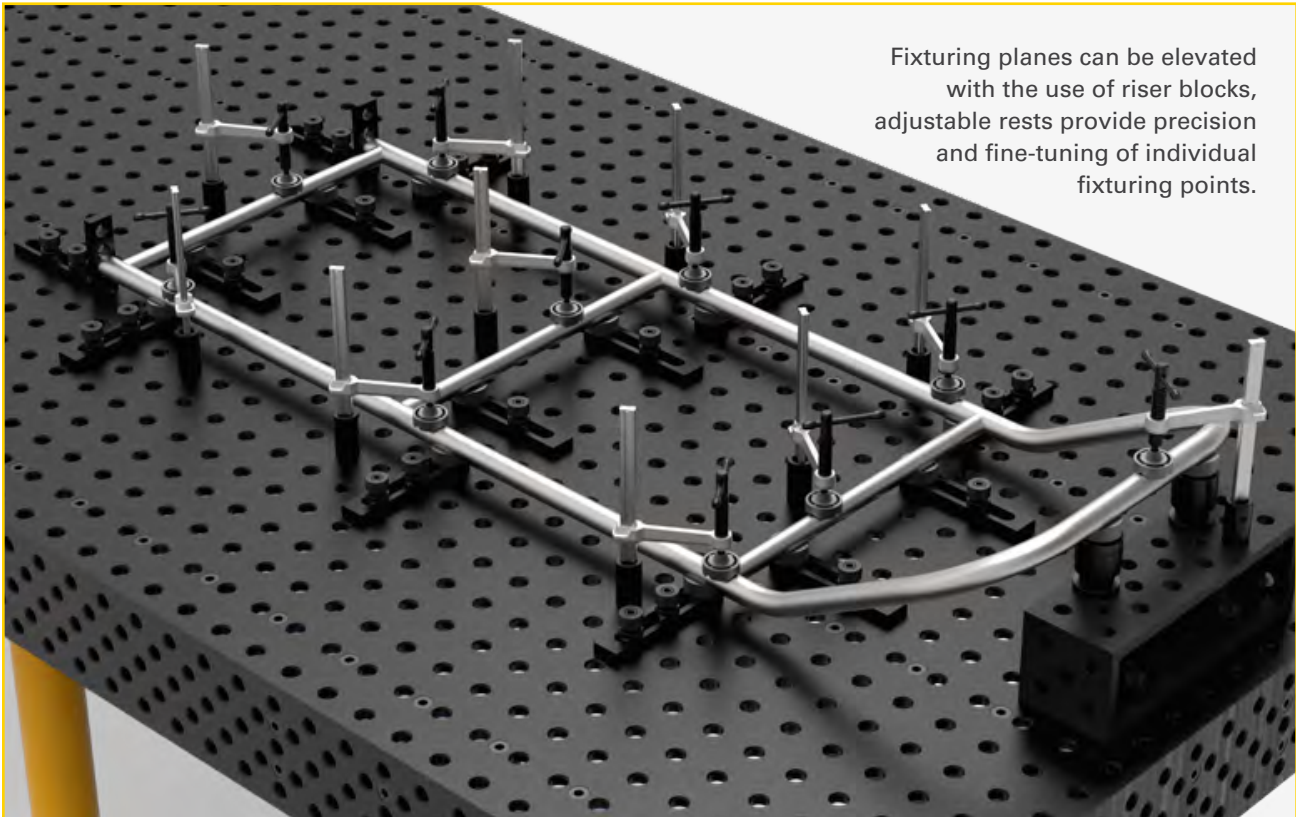

Fixturing planes can be elevated with the use of riser blocks, adjustable rests provide precision and fine-tuning of individual fixturing points.



Laser-cut fixturing components can be joined with modular elements to provide precise positioning, and alignment while maintaining consistency and accuracy.



# FIXTURING EXAMPLES

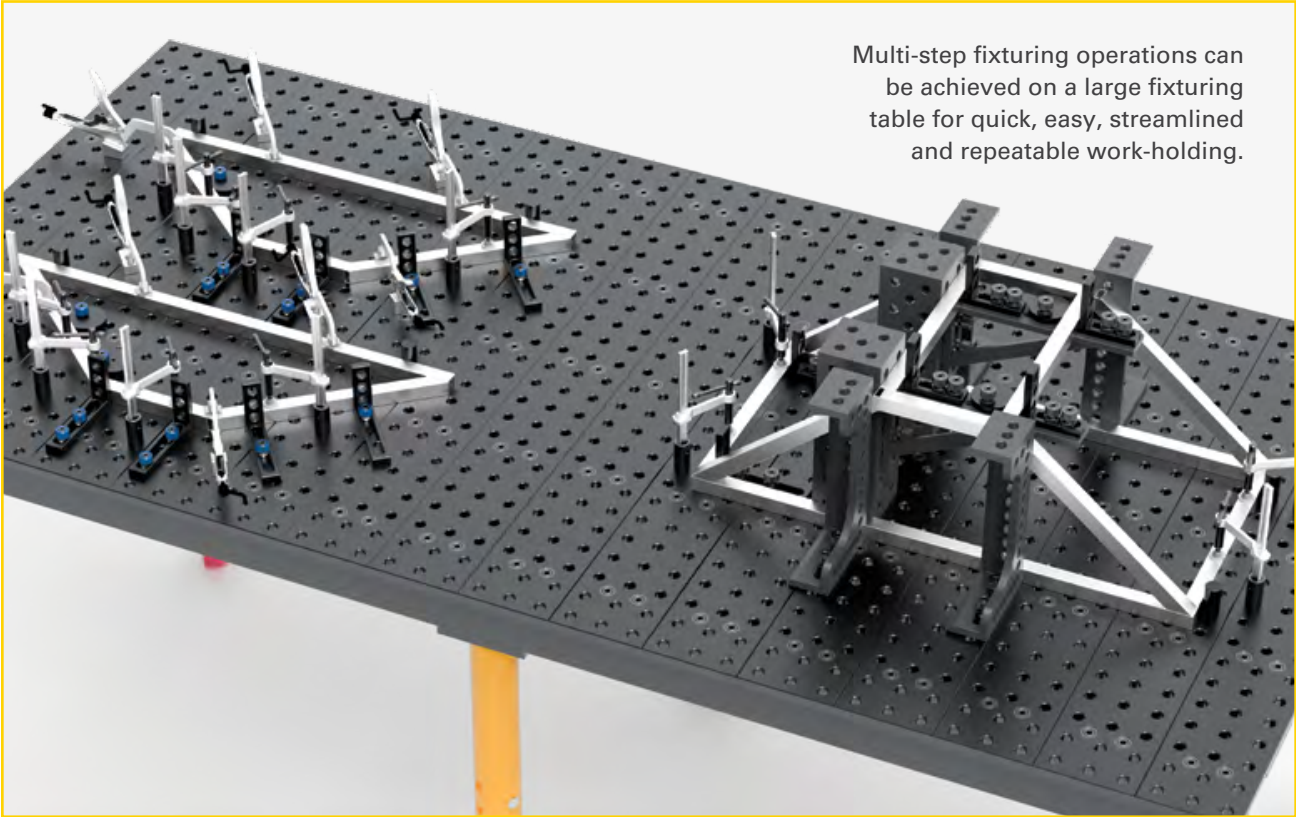

Multi-step fixturing operations can be achieved on a large fixturing table for quick, easy, streamlined and repeatable work-holding.



Clamping squares can be combined with magnetic plugs to easily square and hold up sheet metal panels.



## TOGGLE CLAMPS

Ideal time-saving jig and fixture clamps.

[www.goodhandinc.com](http://www.goodhandinc.com)



VERTICAL HANDLE

*Hold Down Action*

PUSH / PULL

*Straight Line Action*

SIDE MOUNT

F-TYPE

*Pull Down Action*

YOKE ASSEMBLIES

HORIZONTAL HANDLE

*Hold Down Action*

LATCHTYPE

*Pull Action*

TOGGLE PLIERS

*Squeeze Action*

PNEUMATIC POWER

HEAVY DUTY WELDABLE

*Hold Down Action*



## COMPONENTS

Standard Machine Parts & Tooling Components.

[www.valtrainc.com](http://www.valtrainc.com)

BEDDING SUPPORTS

FORGED ADJUSTA-CLAMPS

CENTER CAM CLAMPS

HANDWHEELS

CAM ACTION CLAMPS

ADJUSTABLE HANDLES

ROTARYT-SLOT NUTS

CAP SCREW HOOK CLAMPS

HANDKNOBS

LIFTING EYEBOLTS



LEVELING PADS

PINS & LINERS

PLAIN EYEBOLTS

HEAVY DUTY FIXED GLIDES

ROTARYT-SLOT BOLTS

SPRING STOPS

SPEED BALL HANDLES

CRANK HANDLES

T-SLOT BOLTS

T-STRAP BOLTS



# STRONG HAND TOOLS®

Welding Clamps · Magnets · Pliers · Vises · Economy Welding Tables

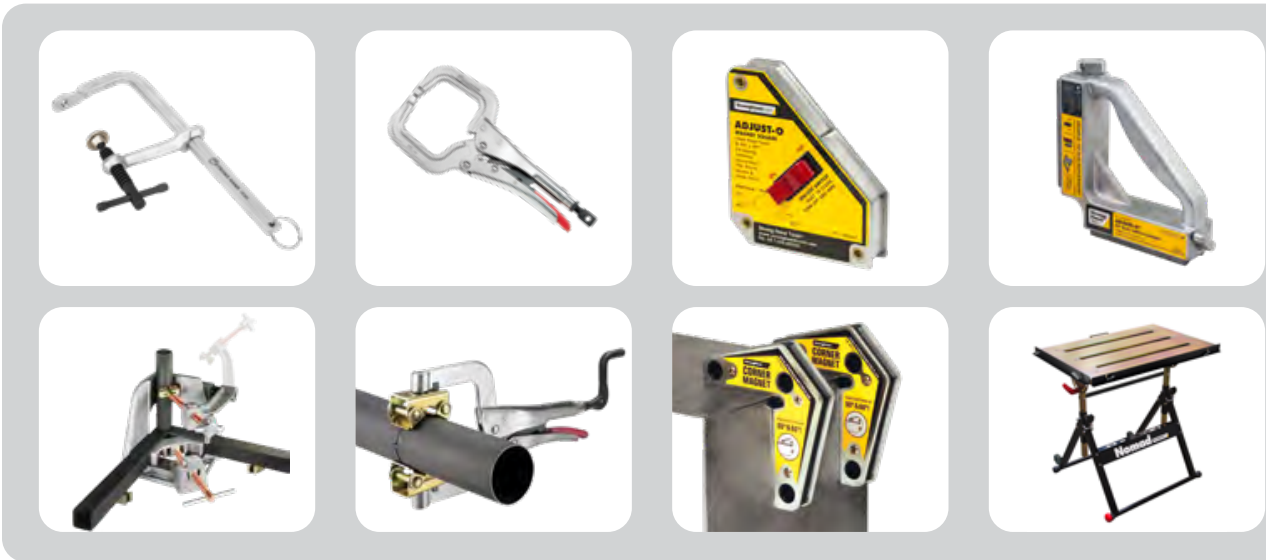

**Please call 800.989.5244 to request the full line catalog.**

Multi-function, time saving Strong Hand Tools® Clamps, Magnets, and Pliers are Quick Acting, so you save time and money by completing work setups faster.



**THE NEXT GENERATION OF AFFORDABLE MODULAR FIXTURING.**

**INDIVIDUAL POSITIONABLE, REVERSIBLE TABLE PLATES**

**58-62 HRC TABLETOP HARDNESS QPQ NITRIDING TREATMENT**



Expand your capabilities in fixturing heavy duty, complex, or oversized weldments for precision welding and fabrication.





#### **USA Headquarters**

8750 Pioneer Blvd, Santa Fe Springs, CA 90670 U.S.A.

Tel: 562-949-8625

Fax: 562-949-4875

sales@stronghandtools.com

#### **Europe**

Pražská 410/11 67401 Třebíč, Czech Republic

Tel: +420 607 088 466

Fax: +420 568 853 213

sales@stronghand.eu

#### **Asia**

No. 605 Huabo Rd, Huating Town, Jiading District, Shanghai, China 201816

Tel: +86-21-59103639

Fax: +86-21-59102951

asiasales@stronghandtools.com

© 2021 First Print. Feb. 2022 Reprint. 03/2023 Edition



CATALOG-BP\_2021\_V2